APPENDIX A

Intersection Selection Memo



San Francisco
County Transportation
Authority



Memorandum

Date: May 17, 2018
To: Jeff Hobson
From: Colin Dentel-Post and Priyoti Ahmed, SFCTA
Subject: Study Intersection Selection Memo

SUMMARY

Over last decade, South of Market area (SoMa) neighborhood experienced tremendous housing and employment growth and will continue to growth in next 20 years. Improving the safety of all road users is essential for ensuring equitable mobility and quality of life for those who live or travel through the SoMa as the region changes. The Transportation Authority and the SFMTA are continuing a collaborative study effort to improve safety at freeway ramp intersections to support progress towards Vision Zero. This memorandum outlines the selection process and criteria for ten study intersections in the SoMa neighborhood for Phase 2 of the Vision Zero Intersection Ramps Study.

BACKGROUND

Phase 1 of the Vision Zero Ramp Intersection Study developed recommendations for improving safety at five SoMa freeway ramp intersections based on detailed crash analyses and other ongoing projects at the ramp intersections. Recommendations for Phase 1 focused on short-term improvements at five locations including signal timing, striping changes, signage improvements, lighting, wayfinding signage, shortening and opening crosswalks. Phase 1 was funded through Prop K D6 NTIP funds, and recommended improvements are expected to be implements as part of SFMTA project and SFMTA's Capital Investment Plan.

Phase 2 of the study will evaluate 10 new freeway ramp intersections in SoMa and recommend short and long terms improvements at those intersections.

Both phases of this study aim to increase safety where high-speed freeway traffic enters neighborhood streets, and the SoMa neighborhood has over 20 ramp intersections. Although Phase 1 of this study focused on high-injury collision locations, Phase 2 of this study aims to proactively improve 10 out of 22 total SoMa freeway ramp intersections that do not have safety improvements planned or recently improved through other infrastructure safety projects.

SELECTION PROCESS

To select the study intersections, the project team analyzed all SoMa freeway ramp intersections' traffic collisions, researched other infrastructure projects in the SoMa that are

already addressing safety issues at freeway ramp intersections, as well as took a proactive approach by looking at design characteristics of existing freeway ramp intersections and ways they could be improved to enhance road user safety.

Traffic Collision Analysis:

The project team evaluated all SoMa freeway ramp intersections based on total number of traffic collisions from 2011 to 2015. The total number of collisions include number of fatalities, severe injuries, visible injuries and any other complaints from traffic collisions. Table 1 shows all SoMa ramp intersections and their total collisions.

Planned and Future Projects:

The project team developed an inventory of all the projects that are proposing safety improvements at SoMa ramp intersections. Some of the planned and ongoing project at SoMa ramp locations are Central Subway Streetscape Project, Harrison Streetscape Project, and Vision Zero Ramps Phase 1 Study. These projects recommendations improve safety and circulation at various SoMa ramp intersection. To avoid any duplicate efforts and to increase safety improvements at all SoMa ramp intersections, the project team only selected intersections that are not already part of another safety projects or studies. Table 1 shows ongoing projects at each ramp intersections in SoMa.

Proactive Approach:

Along with conducting collision analysis and developing inventory of ongoing projects, the project team also assessed each ramp intersection to determine if the intersection can be further improved for all users of transportation. Following this approach, the project team selected intersections that do not have any traffic collisions and are not part of any ongoing projects but can be further improved for safety and traffic circulation. Table 1 shows those ramp intersections that have zero collision and are not part of other projects.

Table 1: SoMa Freeway Ramp Intersections

Intersection	Freeway Ramp Intersection	Project Implementing Safety Improvements	Total Collisions (2011 – 2015)
1	Mission, Otis, Duboce, & 13th streets (U.S. 101 NB off-ramp)	-	32
2	South Van Ness Avenue & 13th Street (U.S. 101 SB on-ramp)	-	25
3	8th Street between Bryant & Harrison streets (I-80 WB off-ramp)	-	0
4	8th Street & Bryant Street (I-80 WB off-ramp)	-	4
5	7th Street & Harrison Street (I-80 WB on-ramp)	-	12
6	7th Street between Bryant & Harrison streets (I-80 EB off-ramp)	-	3
7	7th Street & Bryant Street (I-80 EB off-ramp)	-	6

8	6th Street & Brannan Street (I-280 NB off-ramp, I-280 SB on-ramp)	Brannan Street Safety Project (not addressing ramp itself)	12
9	Fremont Street between Howard & Folsom streets (I-80 WB off-ramp)	-	0
10	Essex Street & Harrison Street (I-80 EB on-ramp)	-	10
11	5th Street & King Street (I-280 NB off-ramp, I-280 SB on-ramp)	SFMTA Project	8
12	5th Street & Harrison Street (I-80 WB off-ramp)	Vision Zero Freeway Ramps Phase 1	20
13	5th Street & Bryant Street (I-80 EB on-ramp)	Vision Zero Freeway Ramps Phase 1	16
14	8th Street & Harrison Street (I-80 WB off-ramp)	Vision Zero Freeway Ramps Phase 1	9
15	9th Street & Bryant Street (U.S. 101 NB off-ramp)	Vision Zero Freeway Ramps Phase 1	10
16	10th Street & Bryant Street (U.S. 101 SB on-ramp)	Vision Zero Freeway Ramps Phase 1	17
17	4th Street & Harrison Street (I-80 WB on-ramp)	Central Subway Streetscape Improvements	16
18	4th Street & Bryant Street (I-80 EB off-ramp)	Central Subway Streetscape Improvements	6
19	Fremont Street & Harrison Street (I-80 WB off-ramp)	Harrison Street Repaving/Streetscape	13
20	1st Street & Harrison Street (I-80 EB on-ramp)	Harrison Street Repaving/Streetscape	10
21	Bryant Street between 2nd Street and Rincon Street (I-80 EB on-ramp)	Safety Treatments Recently Implemented	3
22	Market Street and Octavia Boulevard (U.S. 101 NB off-ramp, U.S. 101 SB on-ramp)	Better Market Street Project	25

SELECTED STUDY INTERSECTIONS FOR PHASE 2:

Based on the selection criteria, the selected intersections for this project are:

1. Mission, Otis, Duboce, & 13th streets (U.S. 101 NB off-ramp)
2. South Van Ness Avenue & 13th Street (U.S. 101 SB on-ramp)
3. 8th Street between Bryant & Harrison streets (I-80 WB off-ramp)
4. 8th Street & Bryant Street (I-80 WB off-ramp)
5. 7th Street & Harrison Street (I-80 WB on-ramp)

6. 7th Street between Bryant & Harrison streets (I-80 EB off-ramp)
7. 7th Street & Bryant Street (I-80 EB off-ramp)
8. 6th Street & Brannan Street (I-280 NB off-ramp, I-280 SB on-ramp)
9. Fremont Street between Howard & Folsom streets (I-80 WB off-ramp)
10. Essex Street and Harrison Street (I-80 EB on-ramp)

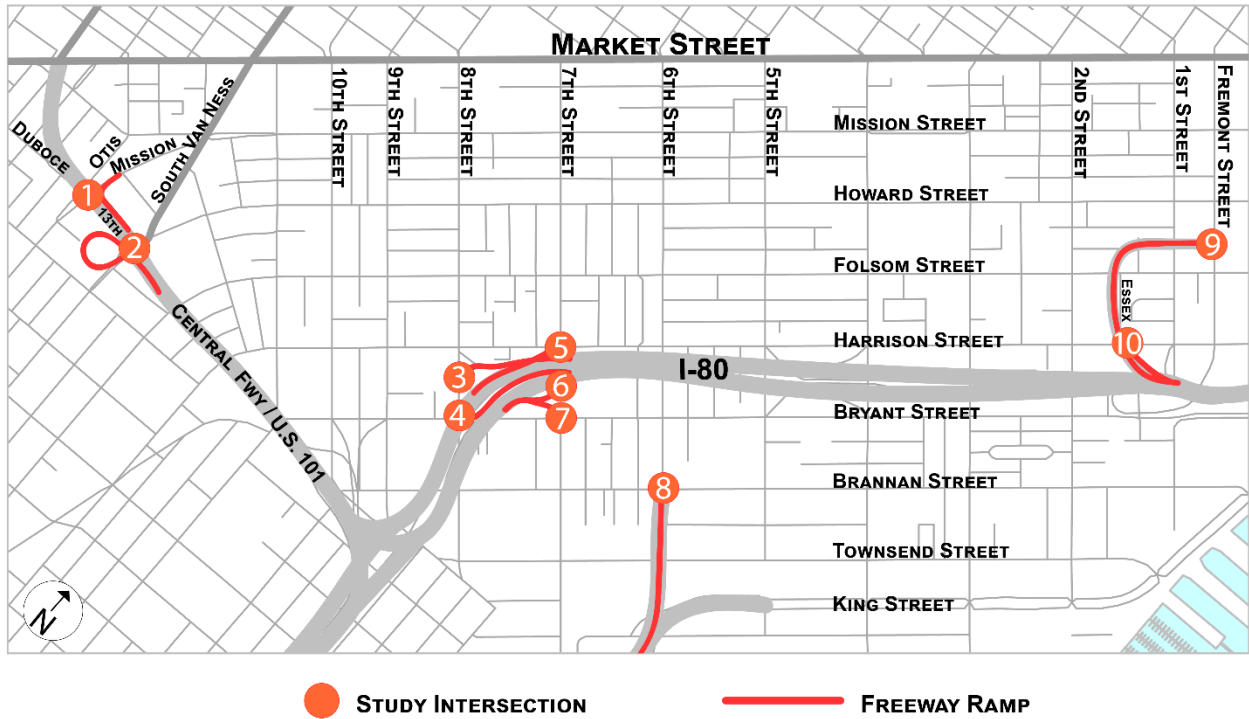

APPENDIX B

Existing Conditions Report



San Francisco
County Transportation
Authority

SoMa Ramp Intersection Safety Study

Existing Conditions Report

April 2018

Prepared for:



Prepared by:



Table of Contents

1	Introduction	1
1.1	Multimodal Network	1
1.2	Planned Projects	1
1.3	Land Use Context.....	1
2	Roadway Design and Traffic Conditions	1
2.1	Roadway and Ramp Design	1
2.2	Congestion	2
2.3	Traffic Speeds	Error! Bookmark not defined.
3	Safety Analysis of Study Intersections and Corridors	5
3.1	Network Collision Analysis	5
3.2	Intersection Analysis.....	8

List of Figures

Figure 1: Study Area and Study Intersections	2
Figure 2: SoMa Multimodal Network.....	1
Figure 3: San Francisco Development Pipeline, 2017	1
Figure 4: Typical Traffic in SoMa, AMPeak	2
Figure 5: Typical Traffic in SoMa, PM Peak.....	3
Figure 6: Typical Traffic Conditions on Study Intersection Ramps.....	4
Figure 7: Collisions by Parties involved	5
Figure 8: Collisions by Parties Involved by Intersection	6
Figure 9: Collision Type for All Intersections	7
Figure 10: Collision Type by Intersection	7
Figure 11: Collision Diagram for Mission Street / 13th Street / US 101 NB Off-Ramp	9
Figure 12: Collision Diagram for South Van Ness Avenue / 13 th Street / US 101 SB On-Ramp	13
Figure 13: Collision Diagram for Bryant Street / 8th Street / I-80 EB On-Ramp.....	18
Figure 14: Collision Diagram for Harrison Street / 7th Street / I-80 WB On-Ramp	21
Figure 15: Collision Diagram for 7th Street (Midblock) / I-80 EB Off-Ramp.....	24
Figure 16: Collision Diagram for Bryant Street / 7th Street / I-80 EB Off-Ramp.....	27
Figure 17: Collision Diagram for Brannan Street / 6 th Street / I-280 On/Off-Ramp	30
Figure 18: Collision Diagram for Harrison Street / Essex Street / I-80 EB On-Ramp	33

List of Tables

Table 1: Characteristics of Intersection Study Streets.....	1
Table 2: Mission Street / 13th Street / US 101 NB Off-Ramp	10
Table 3: South Van Ness Avenue / 13th Street / US 101 SB On-Ramp Collision Summary.....	14
Table 4: Bryant Street / 8th Street / I-80 EB On-Ramp Collision Summary.....	19
Table 5: Harrison Street / 7th Street / I-80 WB On-Ramp Collision Summary	22
Table 6: 7th Street (Midblock) / I-80 EB Off-Ramp Collision Summary.....	25
Table 7: Bryant Street / 7th Street / I-80 EB Off-Ramp Collision Summary.....	28
Table 8: Brannan Street / 6 th Street / I-280 On/Off-Ramp Collision Summary	31
Table 9: Harrison Street / Essex Street / I-80 EB On-Ramp Collision Summary	34

1 Introduction

The SoMa Ramp Intersection Safety Study (Study) seeks to improve safety for all road users in the South of Market (SoMa) neighborhood in the City of San Francisco. The study focuses on intersections where freeway ramps intersect with City streets and consists of two phases. Vision Zero Ramp Phase 1 focused on developing short-term safety improvements at five intersections and was completed in May 2018. This Study analyzes traffic collisions at an additional ten intersections and develops long-term and short-term improvements intersections.

Figure 1 illustrates the study area and intersections, most of which are along 7th, 8th, and 13th Streets. The 10 study intersections shown are:

1. Mission Street / 13th Street / US 101 NB Off-Ramp
2. South Van Ness Avenue / 13th Street / US 101 On-Ramp
3. 8th Street (Midblock) / I-80 WB Off-Ramp
4. Bryant Street / 8th Street / I-80 EB On-Ramp
5. Harrison Street / 7th Street / I-80 WB On-Ramp
6. 7th Street (Midblock) / I-80 EB Off-Ramp
7. Bryant Street / 7th Street / I-80 EB Off-Ramp
8. Brannan Street / 6th Street / I-280 On/Off-Ramp
9. Harrison Street / Essex Street / I-80 EB On-Ramp
10. Fremont Street / I-80 WB Off-Ramp

1.1 MULTIMODAL NETWORK

Figure 2 shows the MUNI transit routes (dashed black) and SFMTA bicycle network (green).

There are existing bike routes along the entirety of 7th and 8th Streets. Bicycle lanes exist on 13th Street to the east of the study intersections, but they end at Folsom St. There are currently no bicycle facilities along Brannan, Bryant, and Harrison Streets east of 11th Street in SoMa. There are also no bike lanes on 6th, Mission, or South Van Ness. There are existing transit routes along all study corridor streets, except South Van Ness Avenue and Fremont Street at the study intersections.

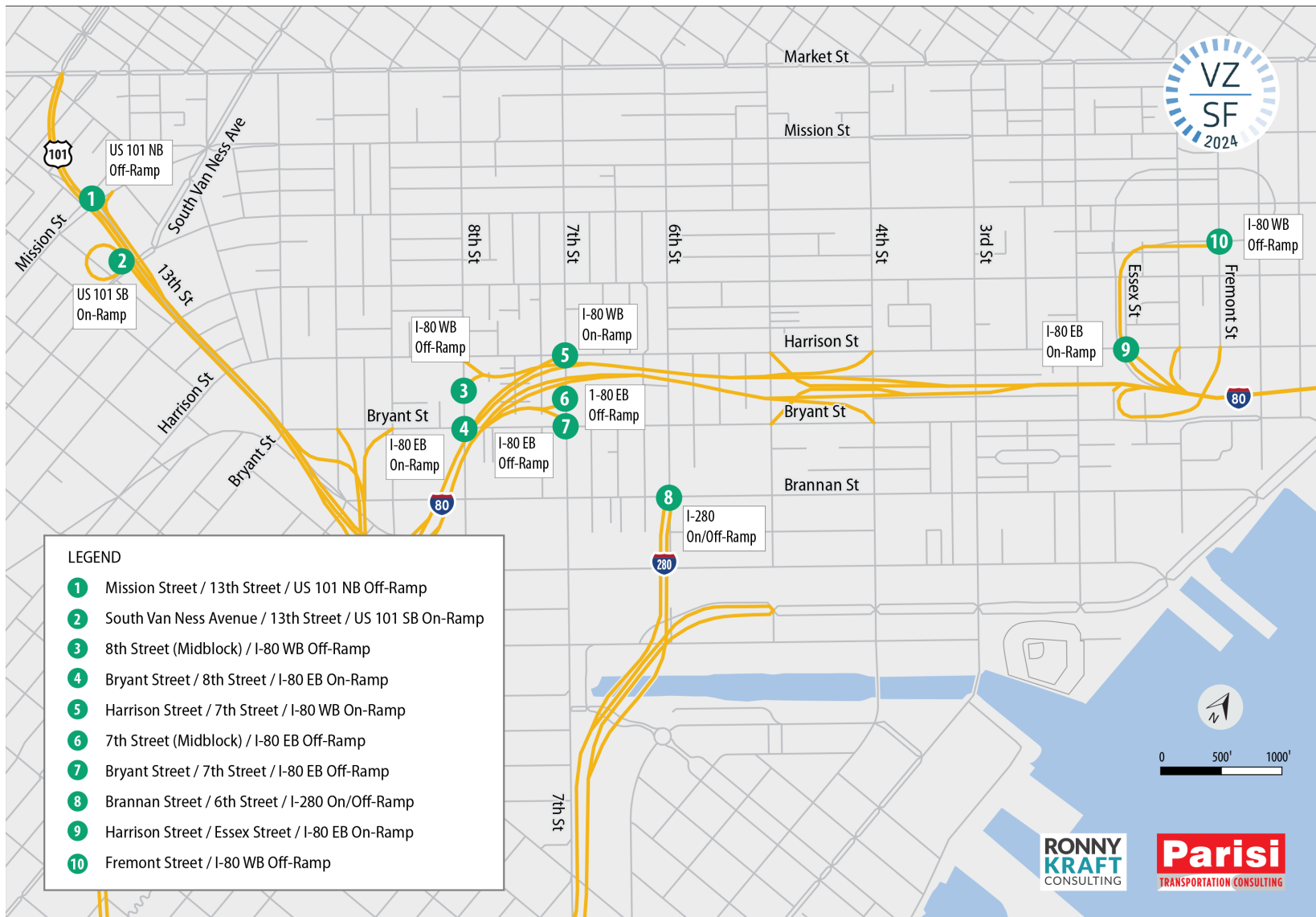

Figure 1: Study Area and Study Intersections

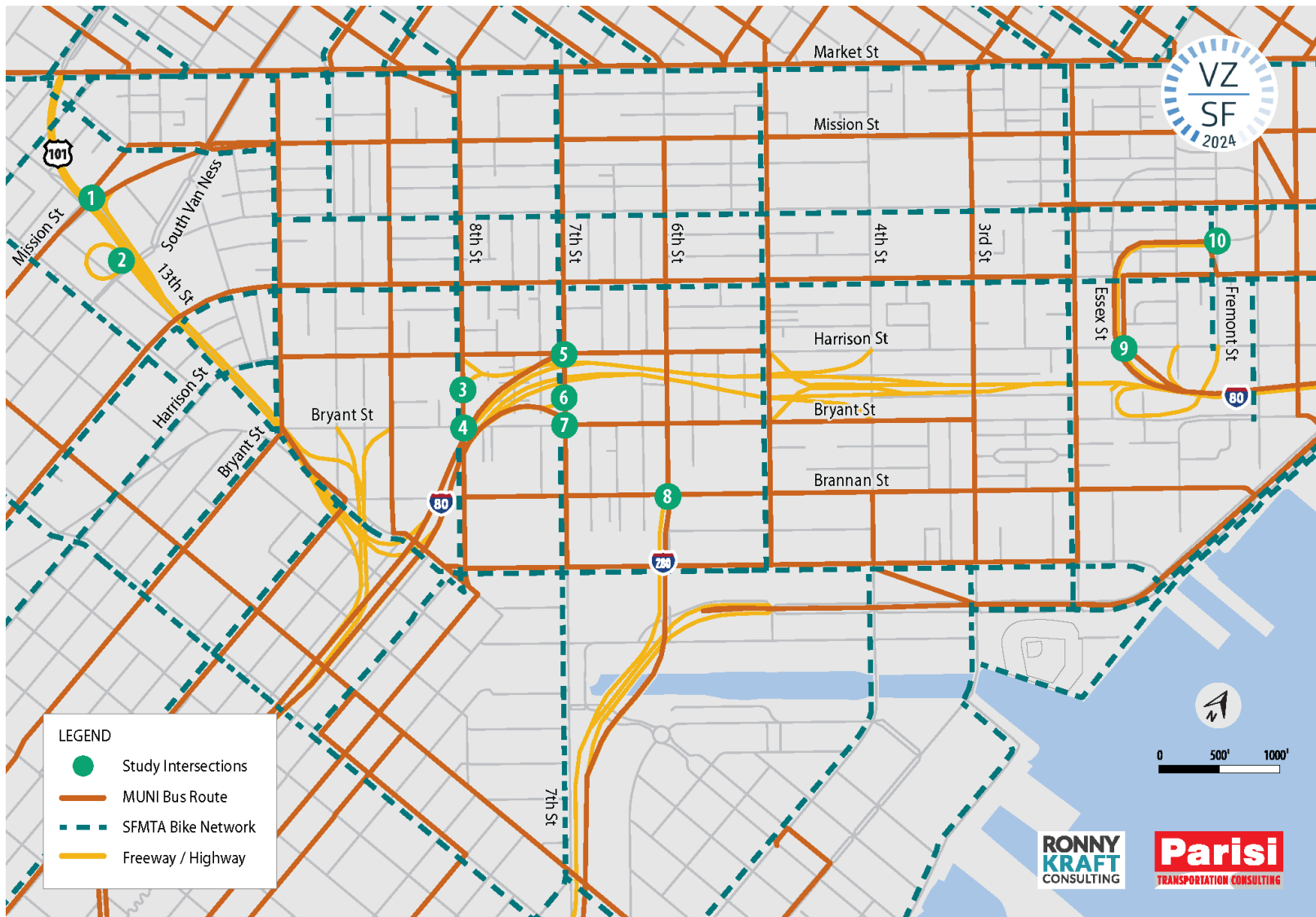

Figure 2: SoMa Multimodal Street Network

1.2 PLANNED PROJECTS

Currently, three planning projects are underway to improve mobility and safety for all road users in the SoMa:

1. **SFMTA's 7th and 8th Streets Safety Project:** The goal of the 7th and 8th Streets Safety Project is to improve safety and comfort for all modes of travel along 7th Street between Market Street and Folsom Street, and 8th Street between Market Street and Townsend Street. This project will implement paint treatments to increase the visibility of people walking and biking as well as concrete elements to provide smoother transit boarding and increased separation between people biking and driving. The project elements include a lane removal, protected bikeways, bus boarding islands, parking removal adjacent to crosswalks to increase visibility of people walking and biking, and signal hardware upgrades.
2. **6th Street Pedestrian Safety Project:** The 6th Street corridor has one of the highest concentrations of pedestrian collisions, injuries, and fatalities in San Francisco. In support of the City's Vision Zero policy, the 6th Street Pedestrian Safety Project aims to create a safe and inviting place for people to walk and bike by transforming 6th Street by adding wider sidewalks, new traffic signals, and streetscape improvements.
3. **Market Street Hub Public Realm Plan:** The San Francisco Planning Department has proposed improvements along 13th Street as part of the Market Street Hub Project that includes two Study intersections—13th and Mission streets and 13th Street and South Van Ness Avenue. The project plans include a reconfiguration of the intersection at 13th and Mission streets, new protected bicycle lane, new curb bulb-outs, improved sidewalks and raised crosswalks, and other new or upgraded pedestrian amenities.
4. **Caltrans Signal Upgrade:** Caltrans is proposing improvements along the 7th and Harrison streets Study intersection to improve efficiency and safety of the traffic signals at this intersection.
5. **Other Improvements from Existing Developer Obligations:** Repaving, curb ramps, and general repairs required per existing development agreements at Essex and Harrison Street and 6th and Brannan Street intersections.

1.3 LAND USE CONTEXT

The SoMa neighborhood is one of San Francisco's fastest-growing. According to a September 2014 report by the San Francisco Planning Department, SoMa is programmed to receive almost 20,000 new residents and 50,000 new jobs by 2040 – more than any other San Francisco Priority Development Area (PDA) and representing 20 percent of all growth in San Francisco by 2040. Without appropriate street safety upgrades, this growth could increase the number of traffic collisions occurring in SoMa, particularly at ramp intersections. Figure 3 illustrates the location of near-term planned developments and their relationship to the study intersections.

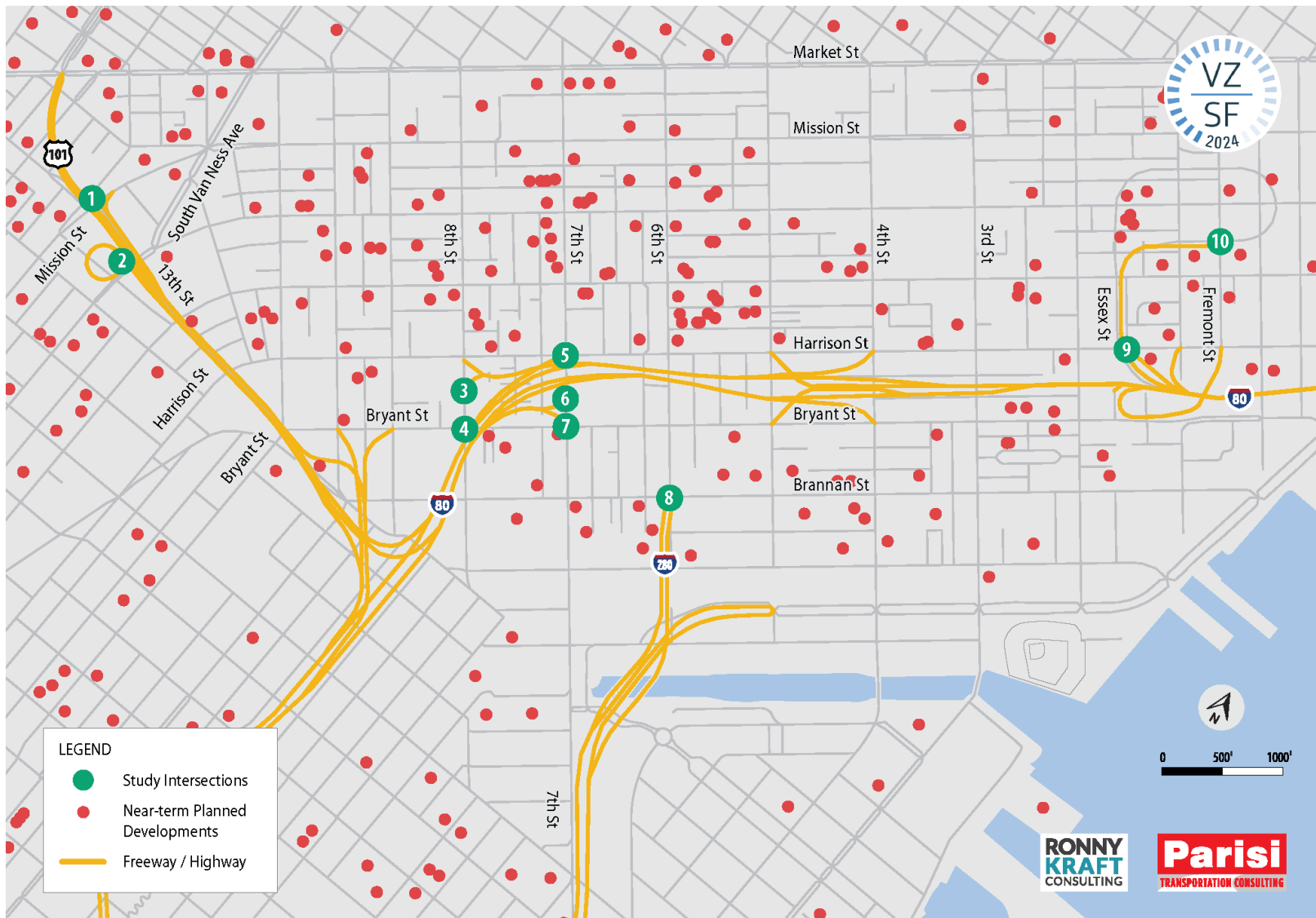

Figure 3: San Francisco Development Pipeline, 2017

2 Roadway Design and Traffic Conditions

This chapter provides an overview of the physical and operational characteristics of the SoMa roadway network, including the number of lanes on each street, whether they operate with one-way or two-way traffic, typical congestion, and typical speed.

2.1 ROADWAY AND RAMP DESIGN

SoMa's roadway network includes the I-80, I-280, and US-101 highways and a grid of 25 mph arterial streets and local streets. Most streets comprising the SoMa roadway grid average four to five lanes. Half of the study corridor streets operate with one-way traffic.

Table 1 summarizes the characteristics of the streets that comprise the study locations.

Table 1: Characteristics of Intersection Study Streets

Street Name	Lanes		Configuration
	Midblock	At Intersection	
6 th Street	5	5	Two-Way
7 th Street (Bryant)	4	4	One-Way
7 th Street (Midblock)	-	4	
7 th Street (Harrison)	4	5	
8 th Street	4	4	One-Way
13 th Street	5 (West of SVN) 6 (East of SVN)	6	Two-Way
Mission Street	-	6 (South of 13 th) 8 (North of 13 th , including Otis)	Two-Way
South Van Ness Avenue	4 (South of 13 th) 5 (North of 13 th)	6	Two-Way
Bryant Street	4	5	One-Way
Brannan St	4 (West of 6 th) 5 (East of 6 th)	5 (West of 6 th) 6 (East of 6 th)	Two-Way
Harrison Street	5	5	One-way (Two-Way at Essex St)
Essex Street	4	4	One-Way
Fremont Street	-	3 (South of intersection) 5 (North of intersection)	Two-Way south of intersection One-Way north of intersection

2.2 CONGESTION

To obtain a general picture of traffic congestion levels, the SoMa streets at the 10 ramp intersections were studied using Google Maps' Typical Traffic feature, which collects speed and location data from users' mobile phones to create an index for vehicle speeds on any given road. Traffic conditions were symbolized using green for uncongested conditions, and dark red for slow/congested conditions. The analysis was done for the weekday AM peak (7am – 9am), off-peak (12pm – 2pm) and PM peak (4pm – 6pm).

AM Peak

Figure 4 illustrates traffic conditions during the AM periods for SoMa. On freeways, traffic is relatively free-flowing on I-80, I-280 S, and US-101 S during the morning commute (7am – 9am) as indicated by Typical Traffic's green rating.

The following freeway segments experience medium to high levels of congestion:

- U.S. 101 N around Mission Street
- I-80 E, which experiences moderate congestion between 5th and 7th Street
- I-280 E around 6th Street

Beginning around 8:15am, eastbound Mission Street and northbound South Van Ness Avenue near 13th Street both experience heavy amounts of congestion. 7th Street also experiences congestion starting around 8:00am. Most of the other streets experience low congestion, if at all.

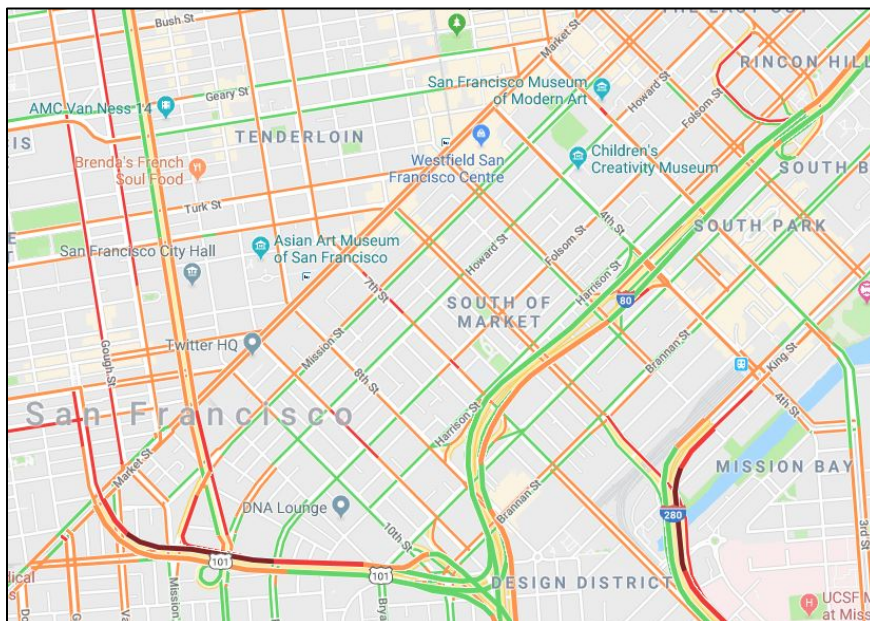

Figure 4: Typical Traffic in SoMa, AM Peak

Source: Google Maps, Typical Traffic Conditions, accessed April 2018.

PM Peak

Figure 5 illustrates traffic conditions during the PM periods for SoMa. Traffic congestion in the PM peak period is significantly worse and widespread than in the morning on all freeways and arterials. The heaviest congested conditions are apparent on I-80 East throughout SoMa. Congestion begins on both I-80 E and US-101 N as early as 12:15pm.

During the PM period, arterial streets within SoMa experience high levels of congestion, especially in the northbound direction towards Market Street and on streets approaching on-ramps.

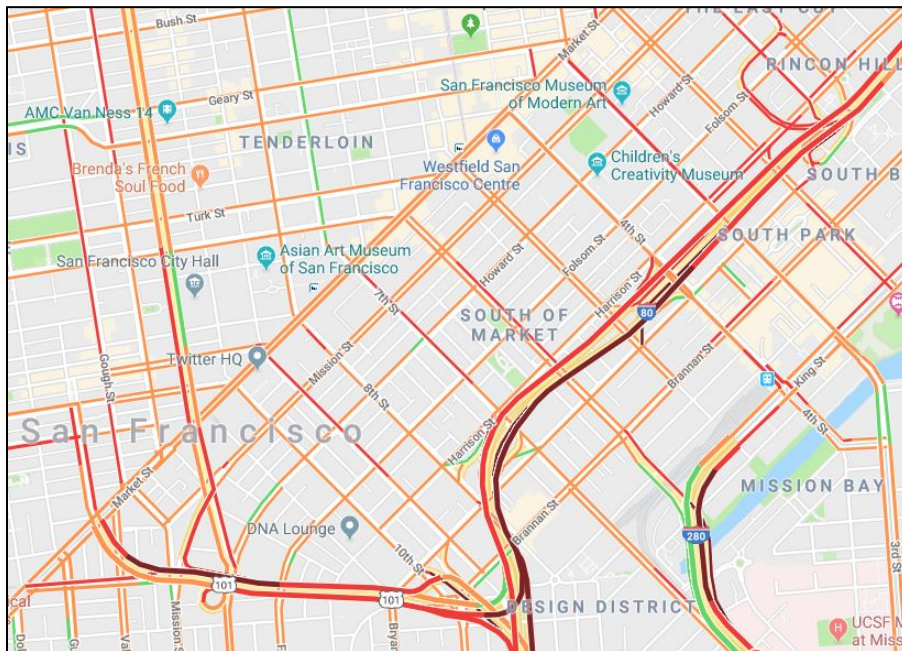





























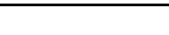
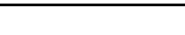
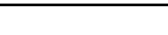





Figure 5: Typical Traffic in SoMa, PM Peak

Source: Google Maps, Typical Traffic Conditions, accessed April 2018.

Ramp Summary

Figure 6 illustrates how congestion affects ramps at the study intersections. The I-280 EB off-ramp onto 6th/Brannan Streets, US 101 NB off-ramp to 13th Street / Mission Street, I-80 WB off-ramp to Fremont Street, and I-80 EB on-ramp from 8th Street /Bryant Street experience the most severe traffic congestion during the day. The I-80 EB off-ramp to 7th Street / Bryant Street is shown as having no congestion, however there is moderate congestion upstream caused by the off-ramp at the midblock of 7th Street. Other ramp intersections experience moderate traffic congestion throughout the day.

Traffic Conditions on Study Ramps	AM Peak (7-9am)	Off-Peak (12-2pm)	PM Peak (4-6pm)
US 101 NB Off-Ramp to 13th/Mission			
US 101 SB On-Ramp from 13th/S Van Ness			
I-80 WB Off-Ramp to 8th (Midblock)			
I-80 EB On-Ramp from 8th/Bryant			
I-80 WB On-Ramp to 7th/Harrison			
I-80 EB Off-Ramp to 7th (Midblock)			
I-80 EB Off-Ramp to 7th/Bryant			
I-280 EB Off-Ramp to 6th/Brannan			
I-280 WB On-Ramp from 6th/Brannan			
I-80 EB On-Ramp to Harrison/Essex			
I-80 WB Off-Ramp to Fremont			

Fast     Slow

Source: Google maps, "Typical Traffic Conditions," 2018

Figure 6: Typical Traffic Conditions on Study Intersection Ramps

3 Safety Analysis of Study Intersections and Corridors

This section analyzes the traffic collision history at the study intersections between 2012-2016 for injury collisions. The dataset includes collisions recorded by the San Francisco Police Department.

At least 133 injury collisions occurred at eight of the study intersections over this period. There were eight severe injury collisions and no fatal collisions during this time period within the study areas. Of the 10 study intersections, only the I-80 WB Off-Ramp / 8th Street midblock intersection did not have any recorded collisions during the study period. Data is not yet available for the newly constructed intersection at the I-80 WB Off-Ramp / Fremont Street intersection.

3.1 NETWORK COLLISION ANALYSIS

Figure 7 shows the different parties involved in the collisions. Slightly more than half (53 percent) of injury collisions involved only vehicles, 19 percent involved a vehicle and a pedestrian, 14 percent involved a vehicle and a cyclist, and seven percent involved a vehicle and a motorcycle/scooter. The “Other” category includes Bicycle / Pedestrian, Vehicle / Motorcycle / Bicycle, solo Vehicle, solo Motorcycle, and solo Bicycle collisions.

There were four collisions for which there was no associated police report.

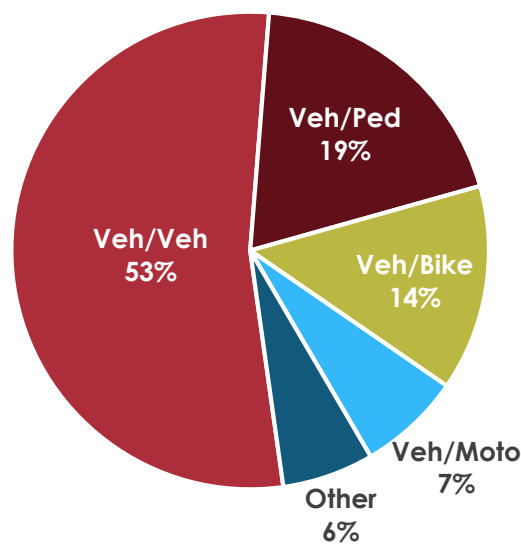

Figure 7: Collisions by Parties Involved

Figure 8 breaks down the different parties involved on an intersection level. Most incidents occur between vehicles, except

- The 7th Street (Midblock) / I-80 EB Off-Ramp intersection had a higher occurrence of vehicle-pedestrian collisions than vehicle-only collisions
- The Harrison Street / Essex Street / I-80 On/Off-Ramp intersection had no vehicle and pedestrian collisions
- The Bryant Street / 7th Street / I-80 EB Off-Ramp had no vehicle-bicycle collisions.

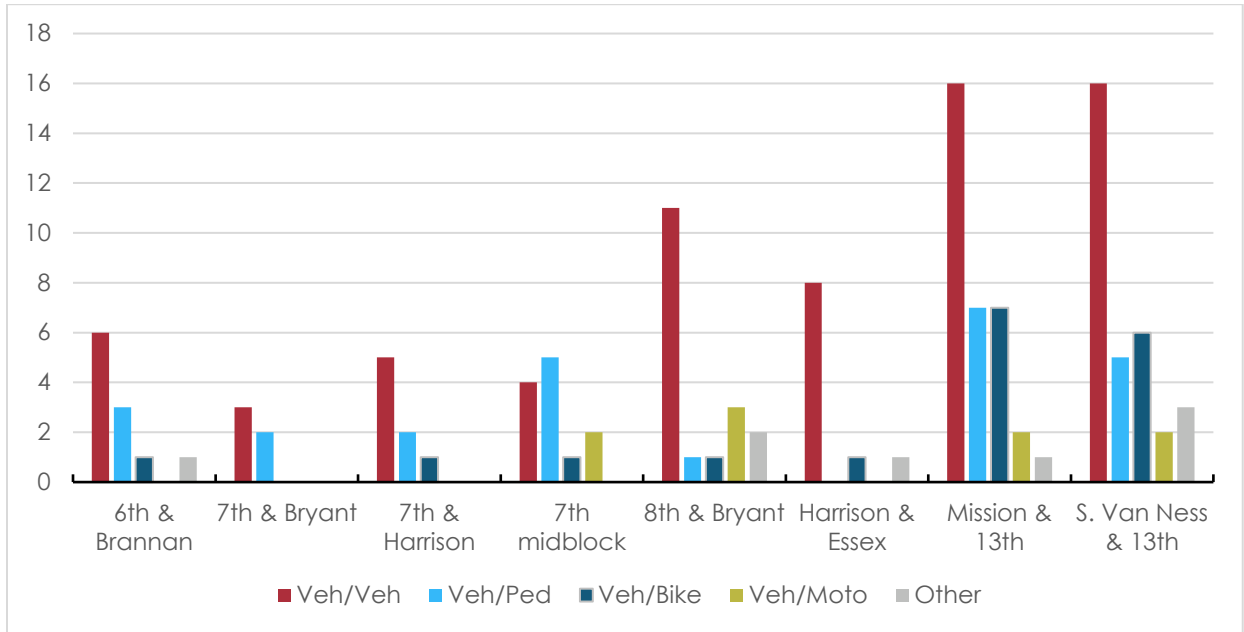

Figure 8: Collisions by Parties Involved by Intersection

Figure 9 and Figure 10 show the breakdown of collisions by type and by intersection. Broadside and rear-ends accounted for 63 percent of collisions. These two collision types could be indications of driver inattention, high vehicular speeds, low visibility of or not obeying signals, or poor sight distance. Broadside collisions were the greatest type of collision for all intersections other than 8th and Bryant Streets. At this intersection, there were twice as many rear-ends as there were broadside collisions. Sideswipe collisions are also a cause for concern as they account for 11 percent of the total collisions and could be caused by driver inattention, lane straddling, unsafe or last-second merging, or general confusion about lane configurations.

There were no direct trends or correlations found for collision rates between peak vs non-peak periods, weekdays vs weekends, by day of week, time of day, or weather conditions.

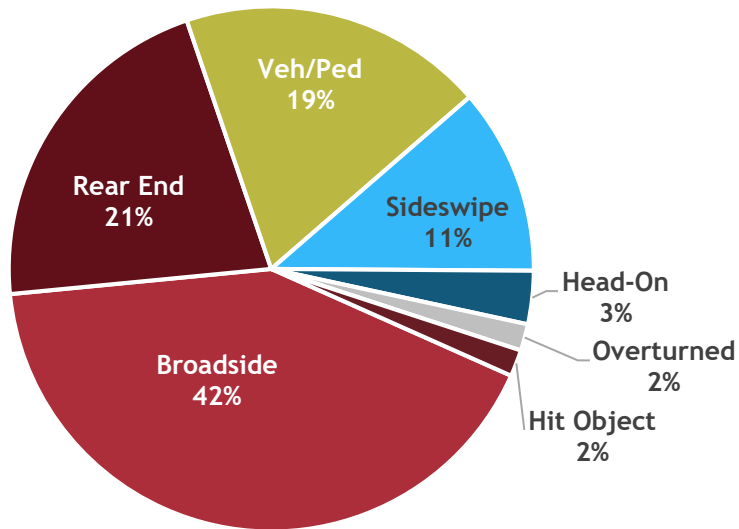

Figure 9: Collision Type for All Intersections

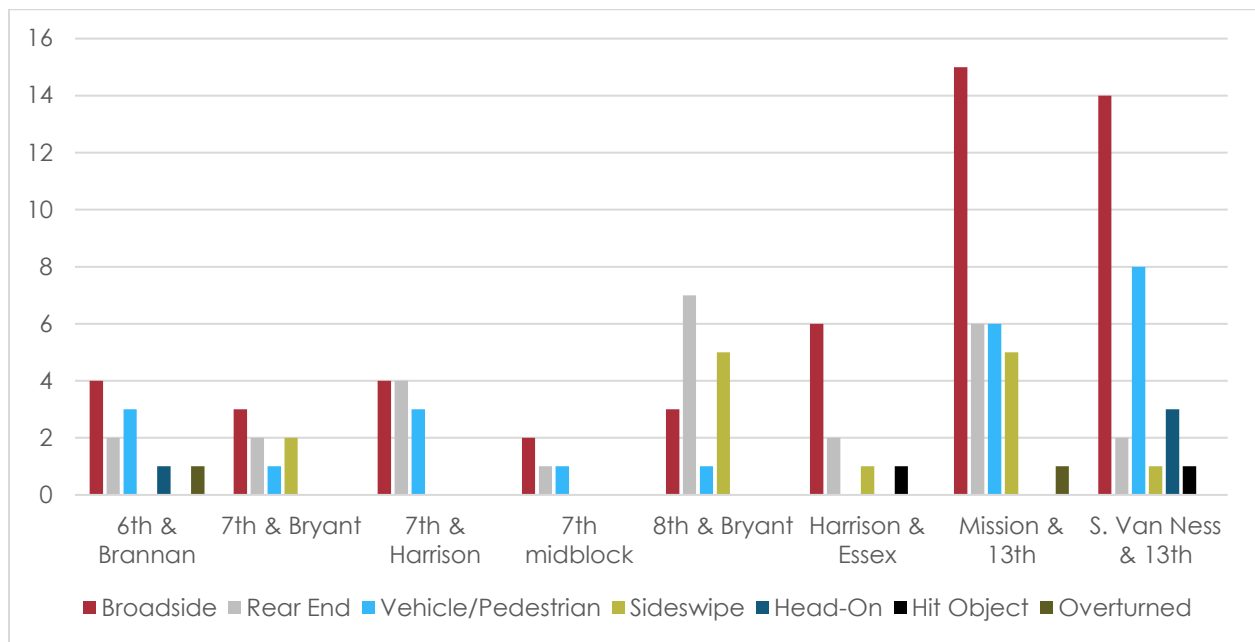

Figure 10: Collision Type by Intersection

3.2 INTERSECTION ANALYSIS

This section gives an existing conditions analysis of each of the study intersections, and includes the collision diagrams and collision summary. The party at fault is shown in red in the diagrams, and the date of each collision is also shown. There were 11 collision reports that did not contain enough information to be diagramed. These are shown in the tables of collisions in italics. "No report" is noted in the ID column for an additional four collisions.

3.2.1 MISSION STREET / 13TH STREET / US 101 NB OFF-RAMP

The following were the observed existing conditions at the intersection of Mission Street / 13th Street / US 101 NB Off-Ramp:

- No high-visibility crosswalks. Pedestrian crossings are wide and may require multiple signal phases to clear the intersection.
- No existing bicycle facilities along any approach
- The intersection is complex because it has more than four approaches, wide medians, staged pedestrian crossings, and turn prohibitions.
- Driver visibility of pedestrians at the off-ramp approaches is hindered by limited sight distance due to approach angle, bridge piers, and low lighting beneath the bridge.

Collision Analysis

The Mission Street / 13th Street / US 101 NB Off-Ramp intersection had the highest number of collisions (35) among the study intersections, with the majority occurring on the eastern half. The intersection also had the highest number of severe injury collisions. There were six collisions with cyclists where the cyclists were found at fault, half of which were due to red light violations. Four collisions occurred from vehicles making illegal left turns from northbound Mission onto westbound Duboce Avenue. Five collisions involving pedestrians occurred in the southeast corner, three involving vehicles making right turns.

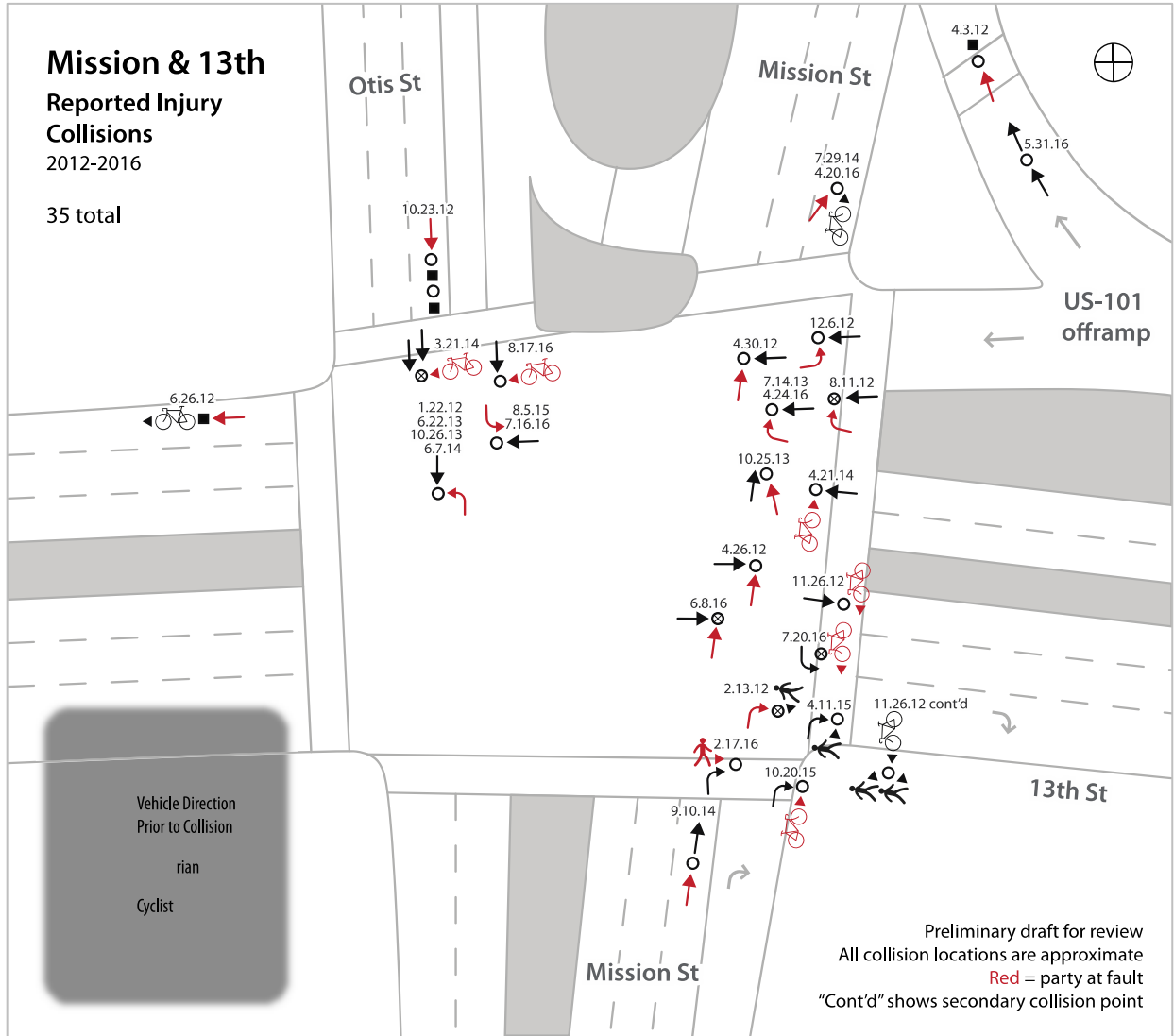

Figure 11: Collision Diagram for Mission Street / 13th Street / US 101 NB Off-Ramp

Table 2: Mission Street / 13th Street / US 101 NB Off-Ramp

Date	Time	Parties Involved	Description	ID
1/10/12	8:30 AM	Veh/Ped	Crossing between controlled intersections	120029035
1/22/12	2:42 PM	Veh/Veh	Ambulance made an illegal left turn	120059612
2/13/12	5:48 PM	Veh/Ped	Driver to yield right-of-way at crosswalks	120124334
4/3/12	2:00 PM	Veh/Veh	Unsafe speed for prevailing conditions	120265405
4/26/12	2:51 AM	Veh/Veh	Under the influence of alcohol or drug	120329459
4/30/12	9:46 PM	Veh/Veh	SFPD vehicle w/ emergency lights on	120344134
6/26/12	11:50 AM	Veh/Bicycle	Driver struck a bicycle from behind	120502495
8/11/12	1:18 PM	Veh/Motorcycle	Driver made an illegal right turn	120636323
10/5/12	8:45 PM	Veh/Ped	Red signal - pedestrian responsibilities	120800493
10/23/12	12:57 PM	Veh/Veh/Veh	Unsafe speed for prevailing conditions	120854064
11/21/12	9:50 AM			No report
11/26/12	10:50 AM	Veh/Bicycle	Red signal - bicycle responsibilities	120955496
12/6/12	8:54 PM	Veh/Veh	Violating special traffic control markers	120985697
6/22/13	1:38 PM	Veh/Veh	Red signal - driver responsibilities	130513040
7/14/13	8:46 AM	Veh/Veh	Violating special traffic control markers	130578163
10/25/13	4:39 PM	Veh/Veh	Failure to use specified lanes	130906542
10/26/13	4:23 PM	Veh/Veh	Violating special traffic control markers	130909295
3/21/14	5:21 PM	Veh/Motorcycle/ Bicycle	Red signal - bicyclist responsibilities	140240233
4/21/14	7:58 AM	Veh/Bicycle	Red signal - bicyclist responsibilities	140329768
6/7/14	6:40 PM	Veh/Veh	Violating special traffic control markers	140475082
7/29/14	9:34 AM	Veh/Bicycle	Unsafe turn or lane change prohibited	140628833
9/10/14	2:10 AM	Veh/Veh	Unsafe speed for prevailing conditions	140763984
4/11/15	7:33 PM	Veh/Ped	Unknown	150314345
8/5/15	6:39 PM	Veh/Motorcycle	Red signal - driver responsibilities	150681683

Date	Time	Parties Involved	Description	ID
10/20/15	4:57 PM	Veh/Ped	Bicycle entering into vehicle path	150917927
2/17/16	8:15 PM	Veh/Ped	Pedestrian suddenly entering into vehicle path close enough to create an immediate hazard	160143338
4/20/16	7:09 PM	Veh/Bicycle	Unsafe passing on right shoulder	160325285
4/24/16	10:15 PM	Veh/Veh	Violating special traffic control markers	160337484
5/31/16	10:45 AM	Veh/Veh	Unsafe speed for prevailing conditions	160444108
6/8/16	7:24 PM	Veh/Veh	Under the influence of alcohol or drug	160468073
6/22/16	9:25 PM	Veh/Ped	<i>Pedestrian suddenly entering into vehicle path close enough to create an immediate hazard</i>	160507621
7/16/16	11:45 PM	Veh/Veh	Red signal - driver responsibilities	160572840
7/20/16	1:10 PM	Veh/Bicycle	Red Signal - bicyclist responsibilities	160585382
8/17/16	12:44 PM	Veh/Bicycle	Red signal - bicyclist responsibilities	160664378
11/30/16	12:42 PM			No Report

3.2.2 SOUTH VAN NESS AVENUE / 13TH STREET / US 101 SB ON-RAMP

The following were the observed existing conditions at the intersection of South Van Ness Avenue / 13th Street / US 101 SB On-Ramp:

- Crosswalks are not the high-visibility type.
- The sidewalk on the south side of EB 13th Street requires pedestrians to cross to the east side of South Van Ness.
- The intersection is wide, which increases exposure to oncoming traffic for pedestrians, bicyclists, and vehicles.
- Due to the intersection width, traffic signals are far away and difficult to see clearly. There are few nearside traffic signals to supplement the primary signal heads.
- No existing bicycle facilities along any approach
- Vehicles on SB South Van Ness Avenue were recorded disregarding the “No Left Turn 4-6PM” restriction.
- The pork-chop island at the southwest corner does not have detectable warning surfaces.
- Bridge piers located within the pedestrian refuges tend to obstruct the pedestrian path.

Collision Analysis

The South Van Ness Avenue / 13th Street / US 101 SB On-Ramp intersection had a very high number of collisions (32). Most occurred in the central area of the intersection, with several due to red light violations and unsafe lane changing or turning. Most vehicles found at fault were heading southbound on South Van Ness or eastbound on 13th Street. Four cyclists were found at fault for collisions within or near crosswalks.

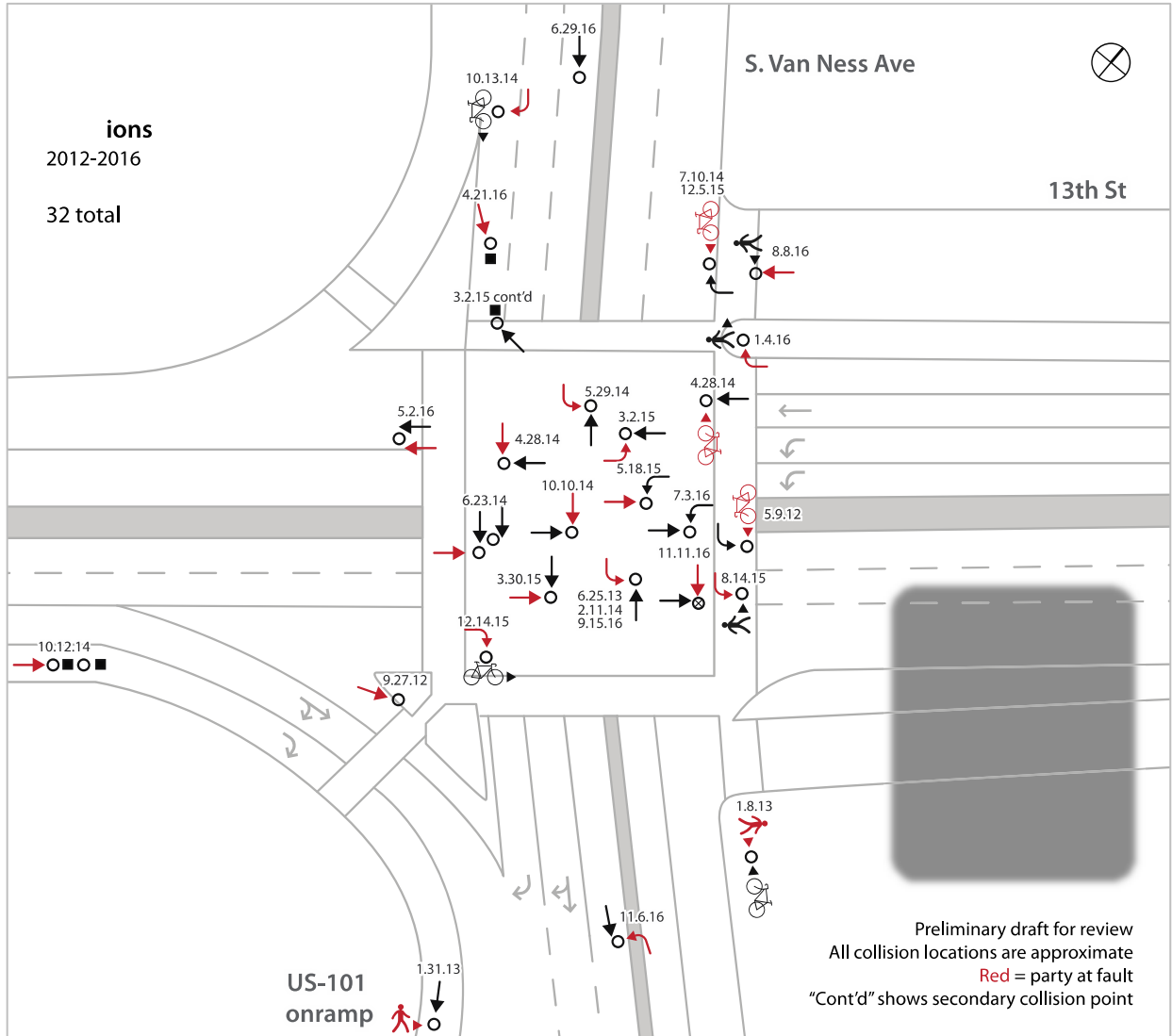

Figure 12: Collision Diagram for South Van Ness Avenue / 13th Street / US 101 SB On-Ramp

Table 3: South Van Ness Avenue / 13th Street / US 101 SB On-Ramp Collision Summary

Date	Time	Parties Involved	Description	ID
5/9/12	10:27 AM	Veh/Bicycle	Bicyclist to yield right-of-way at crosswalks	120368316
9/27/12	12:13 AM	Motorcycle	Unknown	120773919
1/8/13	4:32 PM	Bicycle/Ped	Bicycle to travel in same direction as vehicles	130021413
1/11/13	8:43 PM	Veh/Veh	Unsafe speed for prevailing conditions	130038985
1/31/13	8:59 PM	Veh/Ped	Crossing between controlled intersections	130089530
6/25/13	2:24 AM	Veh/Veh	Red signal - driver responsibilities	130522336
2/11/14	9:05 AM	Veh/Motorcycle	Violation of right-of-way - left turn	140122891
4/28/14	5:54 AM	Veh/Veh	Red signal - driver responsibilities	140350644
4/28/14	2:13 AM	Veh/Bicycle	Red signal - bicyclist responsibilities	140353240
5/29/14	8:19 PM	Veh/Veh	Unsafe turn prohibited	140449792
6/23/14	2:05 AM	Veh/Veh/Veh	Red signal - driver responsibilities	140519179
7/10/14	6:30 PM	Veh/Bicycle	Operating bicycle on sidewalk prohibited	140573852
10/10/14	11:22 AM	Veh/Veh	Red signal - driver responsibilities	140855901
10/12/14	11:26 AM	Veh/Veh/Veh	Unsafe speed for prevailing conditions	140863277
10/13/14	2:15 PM	Veh/Bicycle	Turn at intersection from wrong position	140865693
3/2/15	2:28 PM	Veh/Veh/Veh	Violation of right-of-way - left turn	150189869
3/30/15	2:30 PM	Veh/Veh	Red signal - driver responsibilities	150279658
5/18/15	9:40 AM	Veh/Veh	Red signal - driver responsibilities	150431977
8/14/15	5:54 AM	Veh/Ped	Driver to yield right-of-way at crosswalks	150708306
12/3/15	2:23 PM	Veh/Bicycle	Bicycle to travel in same direction as vehicles	151048240
12/14/15	7:55 AM	Veh/Bicycle	Unsafe turn or lane change prohibited	151078269
1/4/16	8:30 AM	Veh/Ped	Driver to yield right-of-way at crosswalks	160012880
4/21/16	11:20 PM	Veh/Veh	Unsafe turn or lane change prohibited	160329215
5/2/16	3:20 PM	Veh/Veh	Violating special traffic control markers	160362356
6/29/16	7:44 PM	Moto	Unknown	160528401

Date	Time	Parties Involved	Description	ID
7/3/16	7:03 PM	Veh/Veh	Red signal - driver responsibilities	160539408
8/8/16	6:09 PM	Veh/Ped	Driver to yield right-of-way at crosswalks	160639713
9/15/16	11:24 AM	Veh/Veh	Violation of right-of-way - left turn	160749823
10/24/16	11:00 AM	Veh/Veh/Veh	Unsafe speed for prevailing conditions	160865792
11/6/16	11:19 AM	Veh/Moto	Unsafe turn or lane change prohibited	160904265
11/7/16	7:45 AM	Veh/Ped	Pedestrian suddenly entering into vehicle path close enough to create an immediate hazard	160907162
11/11/16	11:45 PM	Veh/Veh	Red signal - driver responsibilities	160912365

3.2.3 8TH STREET (MIDBLOCK) / I-80 WB OFF-RAMP

The following were the observed existing conditions at the intersection of 8th Street (Midblock) / I-80 EB Off-Ramp:

- Intersection is yield controlled
- Shrubbery and the approach angle obstruct the visibility of pedestrians in the southeast corner from drivers approaching from the off-ramp.

Collision Analysis

There were no collisions recorded at this location during the study period.

3.2.4 BRYANT STREET / 8TH STREET / I-80 EB ON-RAMP

The following were the observed existing conditions at the intersection of Bryant Street / 8th Street / I-80 EB On-Ramp:

- The bike lane on NB 8th Street, upstream of Bryant, discontinues at the bus stop; there are no queuing areas marked for bicyclists at the intersection
- Vehicles were observed entering the tow-away lane at high speed to cut ahead of queued traffic.
- There is a pedestrian crossing closed across the north leg of Bryant Street
- Due to the intersection width, traffic signals are far away and difficult to see clearly. There are few nearside traffic signals to supplement the primary signal heads.
- There is no sidewalk on the north side of Bryant Street east of 8th Street and no crosswalk across the on-ramp.
- The pedestrian passageway at the southeast corner is obstructed by the bridge columns and, at times, a homeless encampment.
- There appears to be excess vehicle capacity for through traffic on 8th Street.
- During heavy congestion, vehicles try to merge onto the freeway from the non-“freeway-only” lanes

Collision Analysis

The Bryant Street / 8th Street / I-80 EB On-Ramp intersection saw a total of 19 collisions including many collisions between vehicles as a result of unsafe speed. Several collisions occurred from vehicles at fault that were heading SB on 8th. In three collisions, at fault vehicles attempted to avoid the forced freeway onramp and collided with other vehicles.

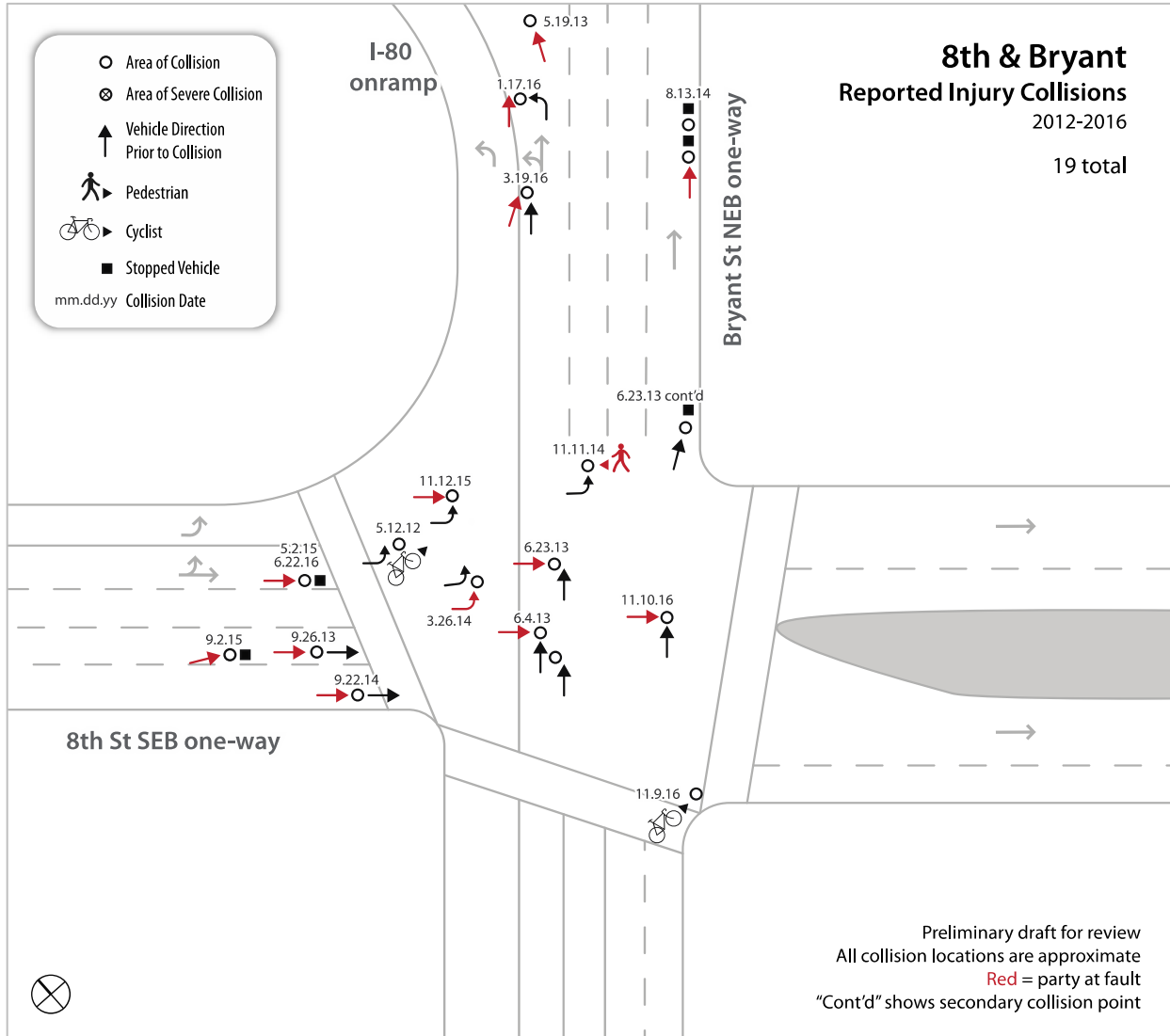

Figure 13: Collision Diagram for Bryant Street / 8th Street / I-80 EB On-Ramp

Table 4: Bryant Street / 8th Street / I-80 EB On-Ramp Collision Summary

Date	Time	Parties Involved	Description	ID
5/12/12	11:40 AM	Veh/Bicycle	Failure to use specified lanes	120377408
5/19/13	1:35 PM	Veh	Drunk driver collided with pillar	130411789
6/4/13	1:54 PM	Veh/Veh/Veh	Red signal - driver responsibility	130460504
6/23/13	12:14 AM	Veh/Veh/Veh	Red signal - driver responsibility	130514543
9/26/13	2:25 AM	Veh/Veh	Unsafe speed for prevailing conditions	130813414
3/26/14	10:00 AM	Veh/Motorcycle	Violating special traffic control markers	140253496
5/1/14	2:22 AM	Veh/Veh	Following too closely prohibited	140361588
8/13/14	3:41 PM	Veh/Veh/Veh	Unsafe speed for prevailing conditions	140676525
9/22/14	12:36 PM	Veh/Veh	Unsafe speed for prevailing conditions	140799644
11/11/14	9:50 PM	Veh/Ped	Crossing between controlled intersections	140957507
5/2/15	2:00 AM	Veh/Veh	Unsafe speed for prevailing conditions	150380879
9/2/15	4:00 PM	Veh/Motorcycle	Unsafe speed for prevailing conditions	150770606
11/12/15	8:20 AM	Veh/Motorcycle	Violating special traffic control markers	150985407
1/17/16	12:00 PM	Veh/Veh	Failure to use specified lanes	160046920
2/17/16	10:40 AM			No report
3/19/16	5:04 PM	Veh/Veh	Unsafe turn or lane change prohibited	160231165
6/22/16	3:30 PM	Veh/Veh	Following too closely prohibited	160506811
11/8/16	4:46 PM	Bicycle	Solo bicycle accident	160911000
11/10/16	6:24 PM	Veh/Veh	Red signal - driver responsibility	160916953

3.2.5 HARRISON STREET / 7TH STREET / I-80 WB ON-RAMP

The following were the observed existing conditions at the intersection of Harrison Street / 7th Street / I-80 WB On-Ramp:

- There is a closed pedestrian crossing across the west leg of Harrison Street.
- Large corner curb radii at the southwest corner.
- A lack of nearside traffic signals.

Collision Analysis

The Harrison Street / 7th Street / I-80 WB On-Ramp intersection experienced thirteen total collisions and a relatively high number of collisions involving pedestrians (four). Many collisions were due to red light violations or unsafe speed.

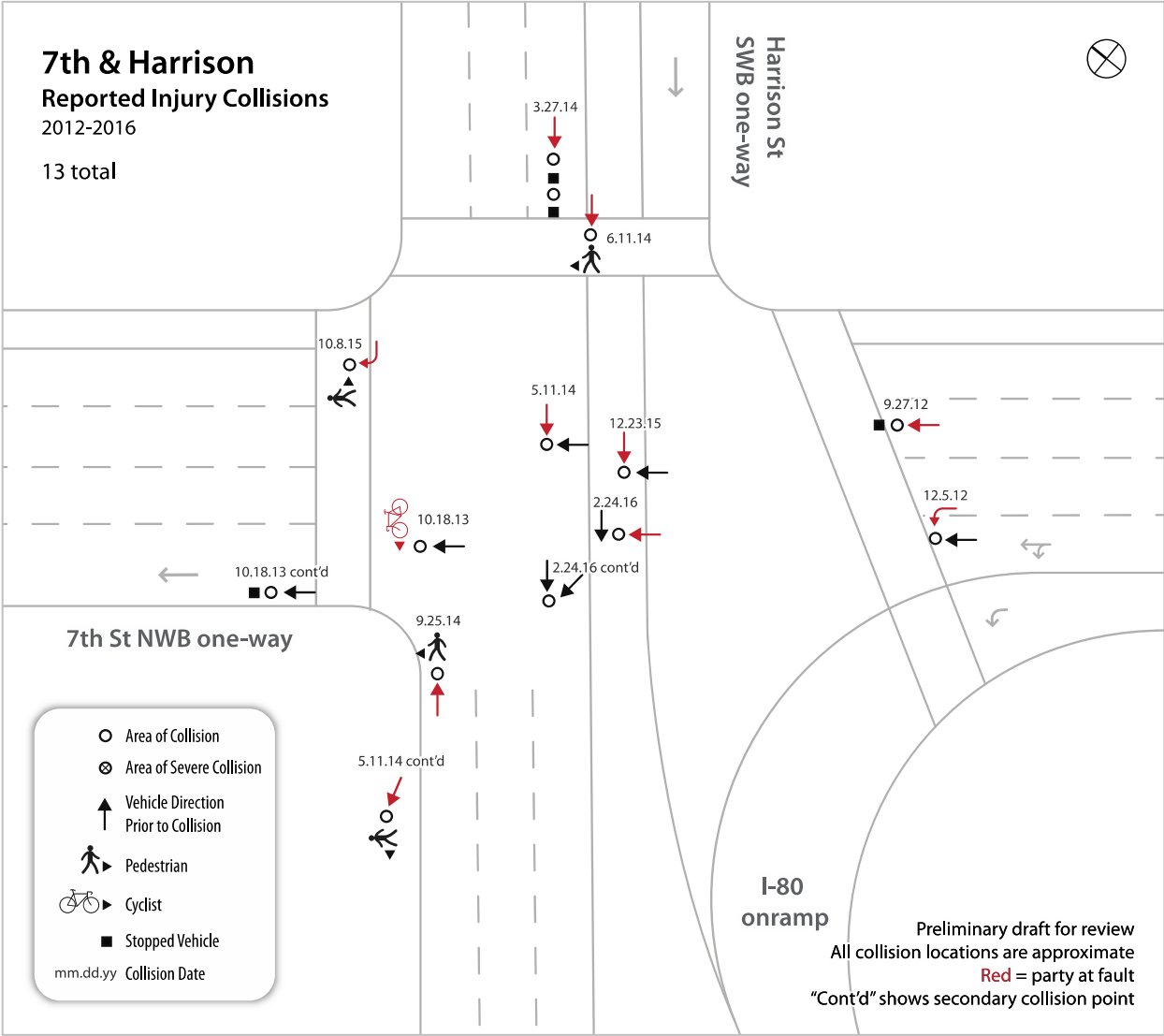

Figure 14: Collision Diagram for Harrison Street / 7th Street / I-80 WB On-Ramp

Table 5: Harrison Street / 7th Street / I-80 WB On-Ramp Collision Summary

Date	Time	Parties Involved	Description	ID
9/27/12	4:40 PM	Veh/Veh	Following too closely prohibited	120775909
12/5/12	2:45 PM	Veh/Veh	Unsafe turn or lane change prohibited	120980409
10/18/13	9:05 AM	Veh/Veh/Bicycle	Red signal - bicyclist responsibility	130882146
12/29/13	1:50 AM	Veh/Veh	Under the influence of alcohol or drug	131091548
3/27/14	3:49 PM	Veh/Veh/Motorcycle	Unsafe speed for prevailing conditions	140257501
5/11/14	4:20 PM	Veh/Veh/Ped	Red signal - driver responsibility	140395509
6/11/14	1:28 PM	Veh/Ped	Unsafe speed for prevailing conditions	140485348
9/25/14	10:45 AM	Veh/Ped	Unsafe starting or backing on highway	140808483
10/8/15	2:17 AM	Veh/Ped	Driver to yield right-of-way at crosswalks	150882079
12/22/15			Unsafe speed for prevailing conditions	No report
12/23/15	1:03 AM	Veh/Motorcycle	Red signal - driver responsibilities	151104290
1/4/16	7:00 PM	Veh/Ped	Unknown - Later Report	160018703
2/23/16	11:25 AM	Veh/Veh/Veh	Red signal - driver responsibilities	160158967

3.2.6 7TH STREET (MIDBLOCK) / I-80 EB OFF-RAMP

The following were the observed existing conditions at the intersection of 7th Street (Midblock) / I-80 EB Off-Ramp:

- Intersection is yield controlled with two off-ramp approach lanes, creating a multiple-threat crossing for pedestrians.
- Pedestrians at the northwest corner have limited sight distance from approaching vehicles in the leftmost lane of the off-ramp.
- The off-ramp intersects 7th Street at a low-approach angle, which encourages higher speeds and reduces sight lines of the driver.

Collision Analysis

7th midblock between Harrison and Bryant saw five collisions. All were clustered in the same area, where the vehicles exit the offramp and must yield to cross traffic. In two collisions, pedestrians were struck in an area of the intersection where visibility is limited for vehicles exiting the offramp.

The 7th Street Midblock off-ramp and 8th Street Midblock off-ramp are very similar in design. The 8th Street Midblock off-ramp, however, has no collisions recorded during the study period compared to the five collisions for 7th Street. One possible reason for this difference is because the 8th Street ramp is a single-lane approach, while the 7th Street ramp is a two-lane approach.

7th Midblock

Reported Injury Collisions

2012-2016

5 total

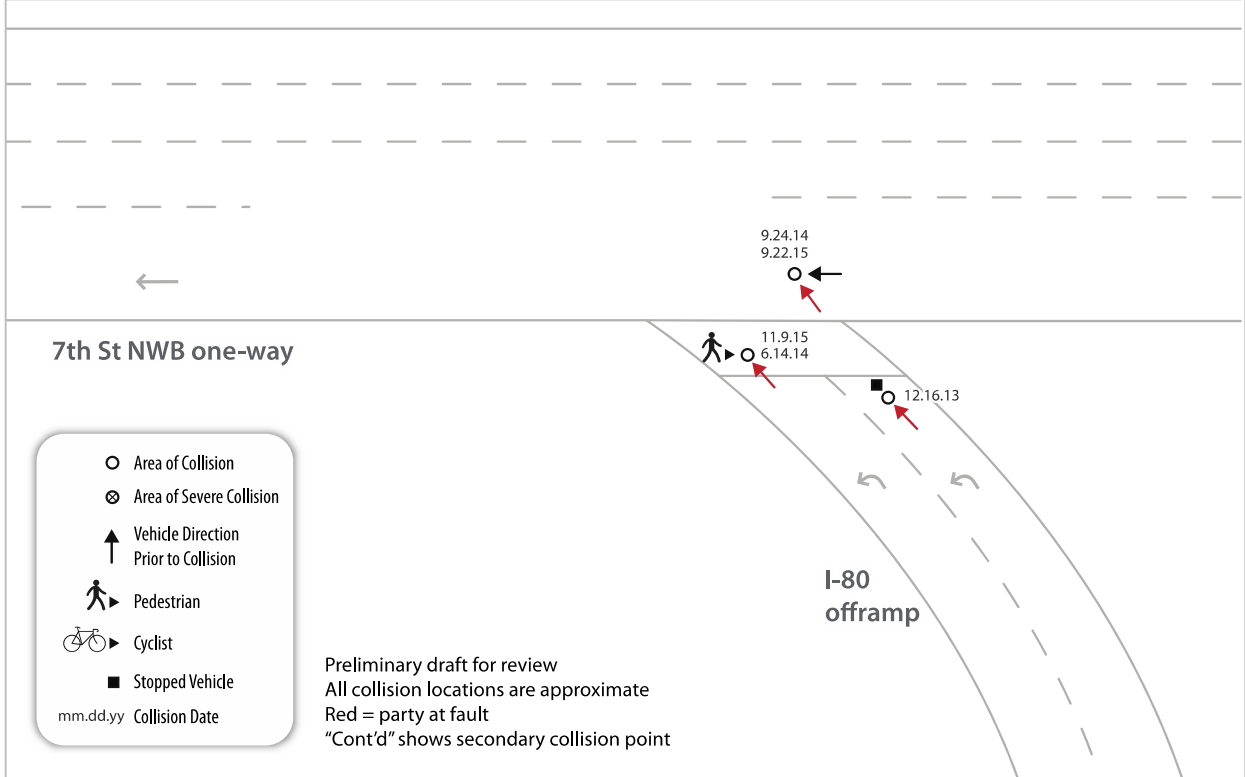

Figure 15: Collision Diagram for 7th Street (Midblock) / I-80 EB Off-Ramp

Table 6: 7th Street (Midblock) / I-80 EB Off-Ramp Collision Summary

Date	Time	Parties Involved	Description	ID
12/16/13	9:40 PM	Veh/Veh	Unsafe speed for prevailing conditions	131057697
6/14/14	8:22 AM	Veh/Ped	Driver to yield right-of-way at crosswalks	140493006
9/24/14	9:13 AM	Veh/Veh	Driver to yield to cross-traffic	140805558
9/22/15	10:16 AM	Veh/Veh	Driver to yield to cross-traffic	150831333
11/9/15	10:58 AM	Veh/Ped	Driver to yield right-of-way at crosswalks	150976973

3.2.7 BRYANT STREET / 7TH STREET / I-80 EB OFF-RAMP

The following conditions were observed at the intersection of Bryant Street / 7th Street / I-80 EB Off-Ramp:

- The intersection is wide, which increases exposure to oncoming traffic for pedestrians, bicyclists, and vehicles
- The bike lane on NB 7th Street does not have protection and there can be conflicts between right-turning traffic and bicyclists at the intersection
- Crosswalks are not the high-visibility type
- The east crossing is especially long and crosses two different EB approaches (from Bryant & I-80 off-ramp)
- Due to the intersection width, traffic signals are far away and difficult to see clearly. There are few nearside traffic signals to supplement the primary signal heads.
- The curb ramp at the northwest corner of the intersection does not meet current ADA standards (no truncated domes)

Collision Analysis

The Bryant Street / 7th Street / I-80 EB Off-Ramp intersection had eight collisions. There were two vehicle vs pedestrian collisions in the same area at the southeast corner. In both cases the at fault vehicle was making a right turn from 7th onto Bryant. There was one bicyclist-involved incident.

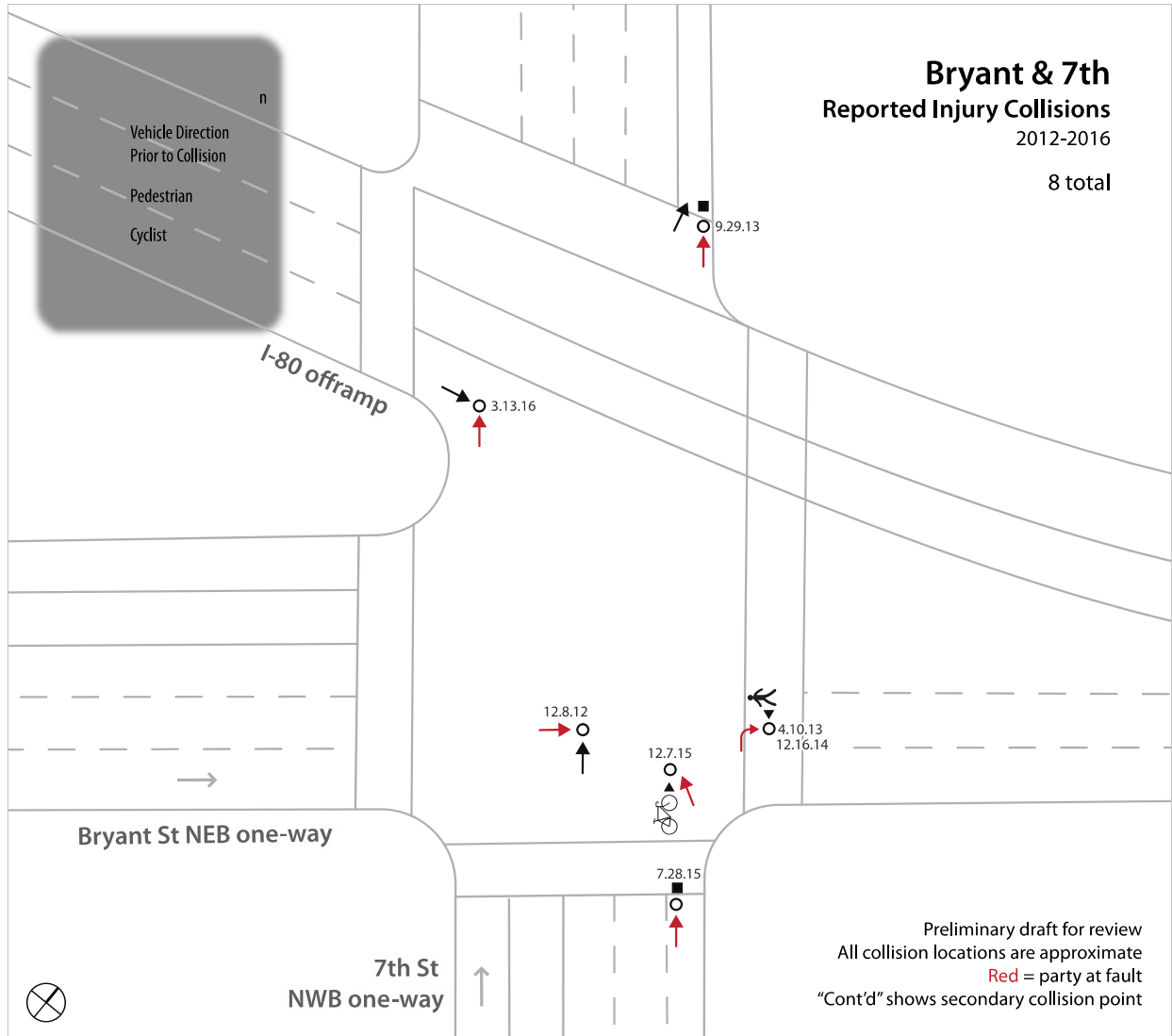

Figure 16: Collision Diagram for Bryant Street / 7th Street / I-80 EB Off-Ramp

Table 7: Bryant Street / 7th Street / I-80 EB Off-Ramp Collision Summary

Date	Time	Parties Involved	Description	ID
12/8/12	4:32 AM	Veh/Veh	Red signal - driver responsibility	120989354
4/10/13	2:49 PM	Veh/Ped	Driver to yield right-of-way at crosswalks	130293208
9/29/13	4:36 AM	Veh/Veh/Veh	Unsafe speed for prevailing conditions	130820776
12/16/14	1:20 AM	Veh/Ped	Driver to yield right-of-way at crosswalks	141036170
7/28/15	3:59 PM	Veh/Veh	Unknown	150656965
12/7/15	7:39 AM	Veh/Bicycle	Unsafe turn or lane change prohibited	151057962
3/13/16	5:09 PM	Veh/Veh	Red signal - driver responsibilities	160212767
4/27/16	4:40 PM	Veh/Veh	Unknown - Later Report	160347405

3.2.8 BRANNAN STREET / 6TH STREET / I-280 ON/OFF-RAMP

The following were the observed existing conditions at the intersection of Brannan Street / 6th Street / I-280 On/Off-Ramp:

- There are no existing bicycle facilities along any approach.
- Crosswalks are not the high-visibility type and are faded. The pedestrian crossing at the south (I-280) approach is closed.
- The approaches along Brannan & 6th Street have no nearside traffic signals.
- The corner curb radii at the I-280 approach are very large.
- Existing curb ramps do not meet current ADA standards.
- The sight distance at the SE corner of pedestrians crossing the east side of the intersection is very limited for approaching off-ramp vehicles.

Collision Analysis

The Brannan Street / 6th Street / I-280 On/Off-Ramp intersection saw eleven total collisions, including three vehicle vs pedestrian collisions in the southeast corner of the intersection. In all three collisions, the vehicle exiting the I-280 offramp and making a right turn onto Brannan was found at fault. The large corner curb radii, shrubbery, and the large changeable message sign pole obstructs the visibility of pedestrians to approaching vehicles at this corner.

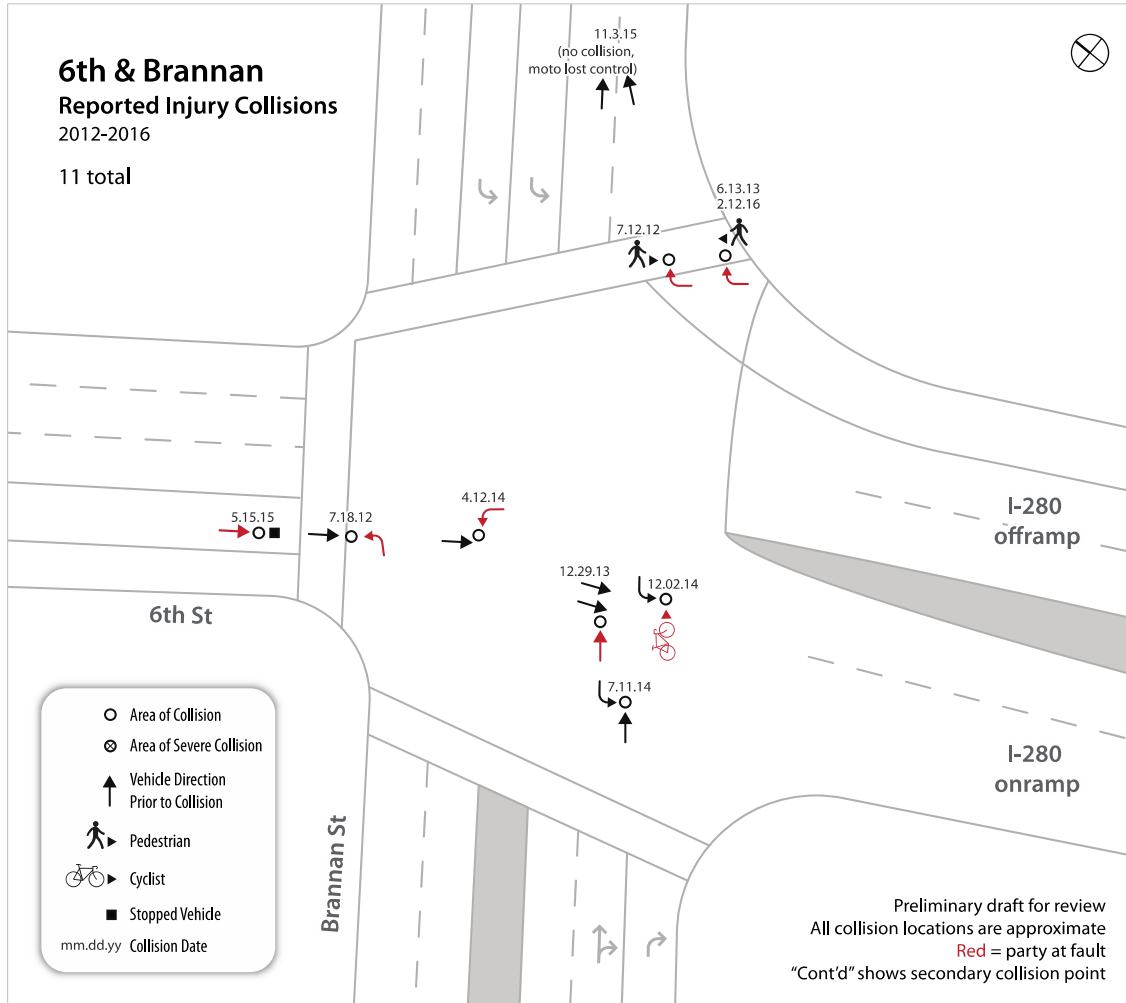

Figure 17: Collision Diagram for Brannan Street / 6th Street / I-280 On/Off-Ramp

Table 8: Brannan Street / 6th Street / I-280 On/Off-Ramp Collision Summary

Date	Time	Parties Involved	Description	ID
3/14/12	4:41 PM	Veh/Veh	Unsafe speed for prevailing conditions	120211088
7/12/12	4:35 PM	Veh/Ped	Driver to yield right-of-way at crosswalks	120549873
7/18/12	9:02 PM	Veh/Veh	Violating special traffic control markers	120568306
6/13/13	8:33 AM	Veh/Ped	Unknown	130486102
12/29/13	4:34 PM	Veh/Veh/Veh	Red signal - driver responsibility	131092881
4/12/14	2:22 AM	Veh/Veh	Violating special traffic control markers	140304936
7/11/14	3:55 PM	Veh/Veh	Unknown	140576184
12/2/14	7:18 PM	Veh/Bicycle	Red signal - bicyclist responsibility	141018338
5/15/15	3:56 PM	Veh/Veh	Unsafe speed for prevailing conditions	150423316
11/3/15	8:29 AM	Motorcycle	Solo motorcycle accident	150959634
2/12/16	8:00 AM	Veh/Ped	Driver to yield right-of-way at crosswalks	160126726

3.2.9 HARRISON STREET / ESSEX STREET / I-80 EB ON-RAMP

The following were the observed existing conditions at the intersection of Harrison Street / Essex Street / I-80 EB On-Ramp:

- Large intersection geometry.
- Crosswalks are not the high-visibility type.
- There are closed pedestrian crossings at the south and west approaches.
- Due to the intersection width, traffic signals are far away and difficult to see clearly. There are few nearside traffic signals to supplement the primary signal heads.
- The existing bridge piers obstruct SB Essex vehicles from seeing WB Harrison Street traffic, and vice-versa.
- There are no existing bicycle facilities along any approach.
- Vehicles on EB Harrison were observed entering the Bus-Only Lane to bypass queues on the I-80 on-ramp

Collision Analysis

The ten collisions at Harrison Street / Essex Street / I-80 EB On-Ramp were relatively clustered in the western portion of the intersection. Many were broadside collisions resulting from a red-light violation or unsafe speed. All but one collision involved only vehicles.

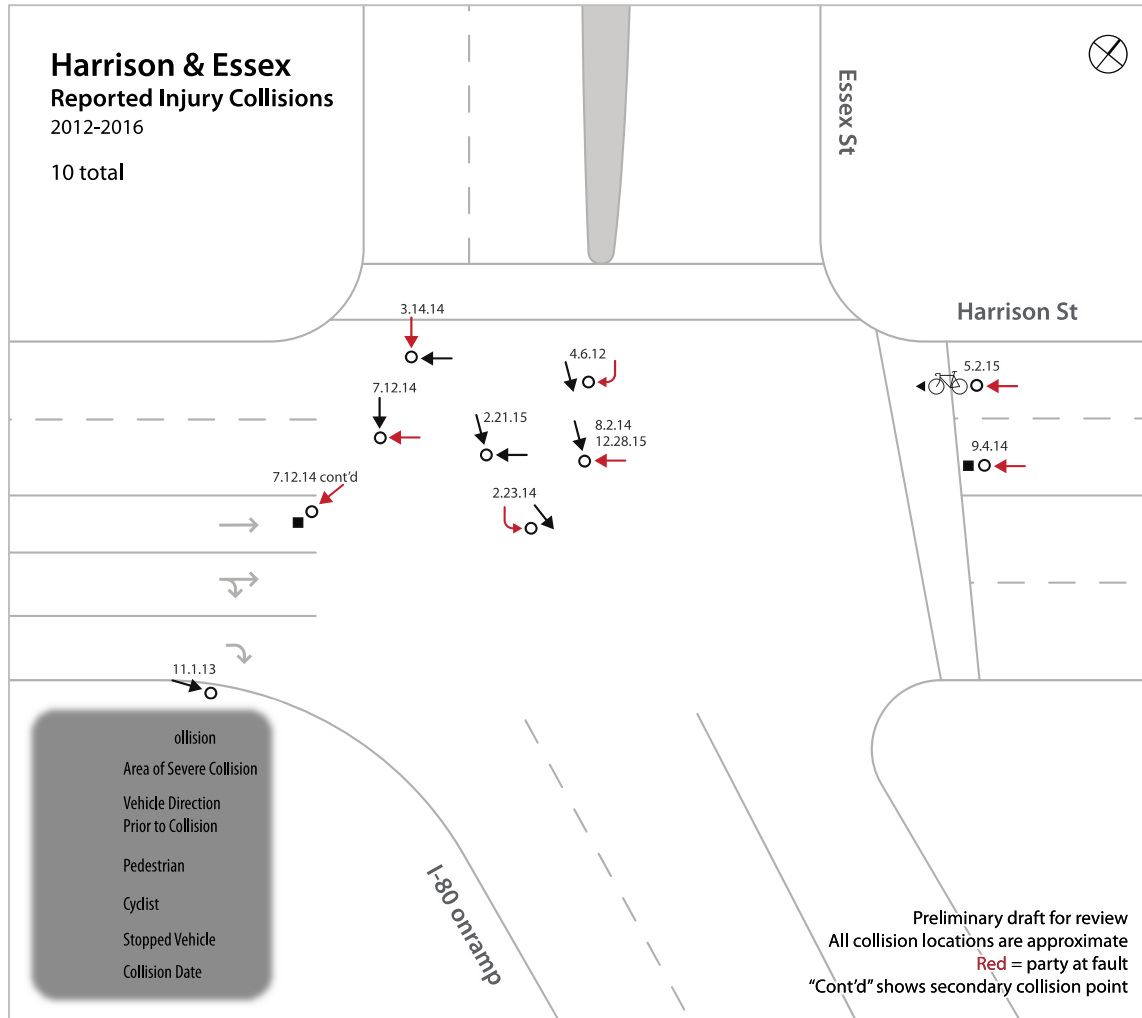

Figure 18: Collision Diagram for Harrison Street / Essex Street / I-80 EB On-Ramp

Table 9: Harrison Street / Essex Street / I-80 EB On-Ramp Collision Summary

Date	Time	Parties Involved	Description	ID
4/6/12	8:49 AM	Veh/Veh	Unsafe turn or lane change prohibited	120273505
11/1/13	12:20 AM	Veh	Improper Turning	130926506
2/23/14	8:11 PM	Veh/Veh	Unsafe turn or lane change prohibited	140160562
3/14/14	7:50 PM	Veh/Veh	Red signal - driver responsibilities	140219012
7/12/14	11:55 AM	Veh/Veh/Veh	Red signal - driver responsibilities	140578517
8/2/14	4:34 PM	Veh/Veh	Unsafe Speed	140642479
9/4/14	9:14 AM	Veh/Veh	Unsafe Speed	140744047
2/21/15	8:25 PM	Veh/Veh	Unknown - Red Light	150161481
5/2/15	2:15 PM	Veh/Bicycle	Unsafe Speed	150381924
12/28/15	1:45 PM	Veh/Veh	Unsafe Speed	151116825

3.2.10 FREMONT STREET / I-80 WB OFF-RAMP

The following were the observed existing conditions at the intersection of Fremont Street / I-80 WB Off-Ramp:

- Crosswalks are not the high-visibility type.
- There are no pedestrian crossings marked across Fremont Street, despite public walkways through new developments on either side of the intersection that create a pedestrian desire line across Fremont Street.
- There are no existing bicycle facilities along Fremont Street
- “No Turn on Red” signs are placed on the far side of the intersection and hard to see.

Collision Analysis

There was no collision data for this location during the study period because the intersection is relatively newly constructed.

APPENDIX C

Technical Drawings



San Francisco
County Transportation
Authority



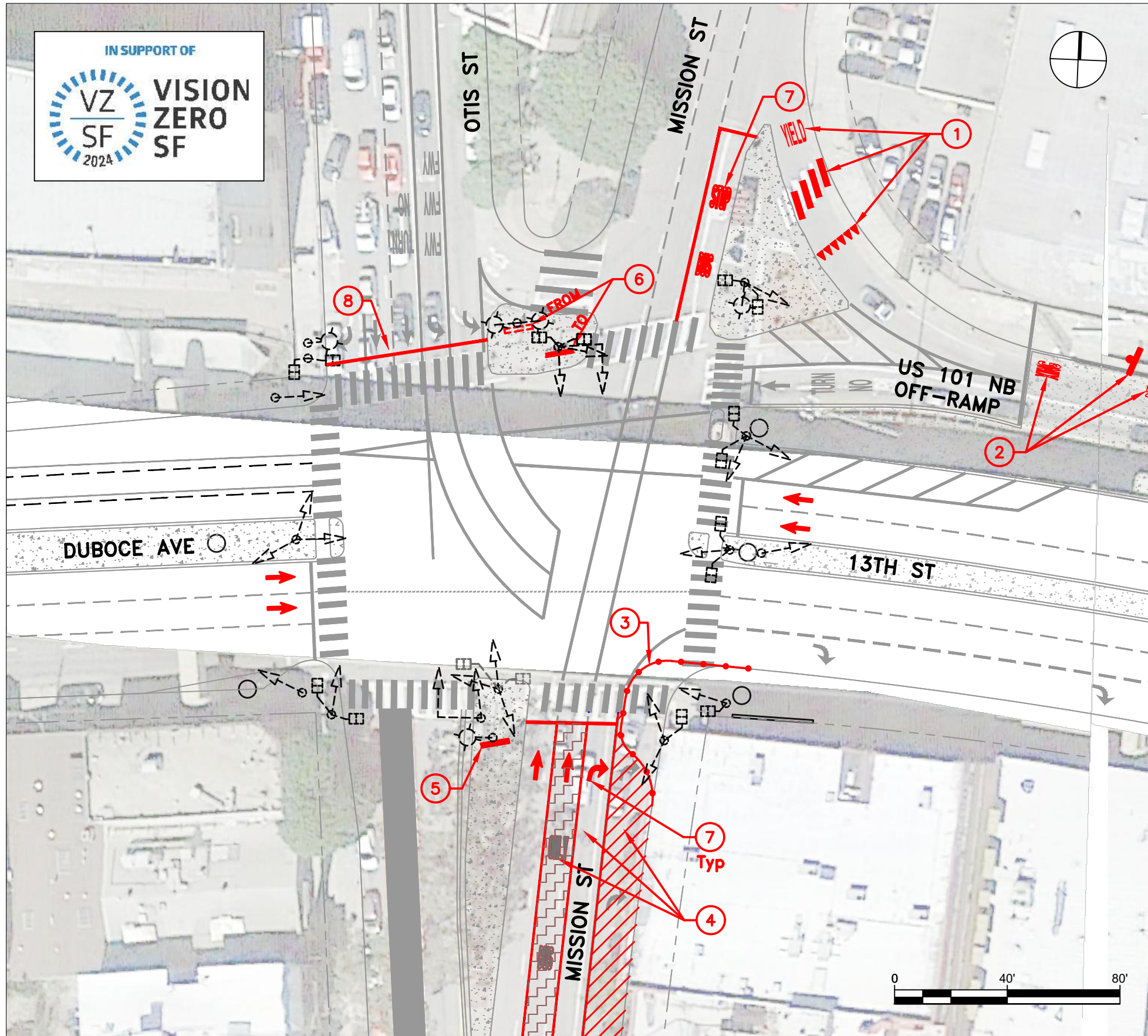

RECOMMENDED IMPROVEMENTS (NEAR-TERM)

- ① YIELD LINE, YIELD STENCIL, AND CONTINENTAL CROSSWALK (IMPLEMENTED BY CALTRANS IN 2018)
- ② STRIPE "PED XING" PAVEMENT MARKINGS IN ADVANCE OF CROSSING. INSTALL "PEDESTRIAN CROSSING AHEAD" WARNING SIGN AND PLAQUE. REQUIRES CALTRANS APPROVAL
- ③ INSTALL BULB-OUT USING TEMPORARY MATERIALS (E.G. DELINEATORS AND PAINT) FOR NEAR-TERM IMPLEMENTATION
- ④ CONVERT #2 LANE TO BUS-ONLY LANE. CONVERT #3 LANE TO RIGHT-TURN-ONLY LANE AND REMOVE #4 LANE. LANE RECONFIGURATIONS MAY REQUIRE SHIFTING OF OVERHEAD MUNI LINES. NEW BUS LANE REQUIRES FURTHER STUDY
- ⑤ INSTALL ADDITIONAL NEAR-SIDE "NO LEFT TURN" SIGN
- ⑥ RELOCATE FARSIDE "NO LEFT TURN" SIGN TO SIGNAL POLE
- ⑦ STRIPE PAVEMENT MARKING ARROWS TO REINFORCE LANE ASSIGNMENT
- ⑧ STRIPE ADVANCE STOP BAR

MISSION STREET/13TH STREET/US 101 NB OFF-RAMP

VISION ZERO PHASE 2 RAMP INTERSECTION IMPROVEMENTS

FEBRUARY 2019

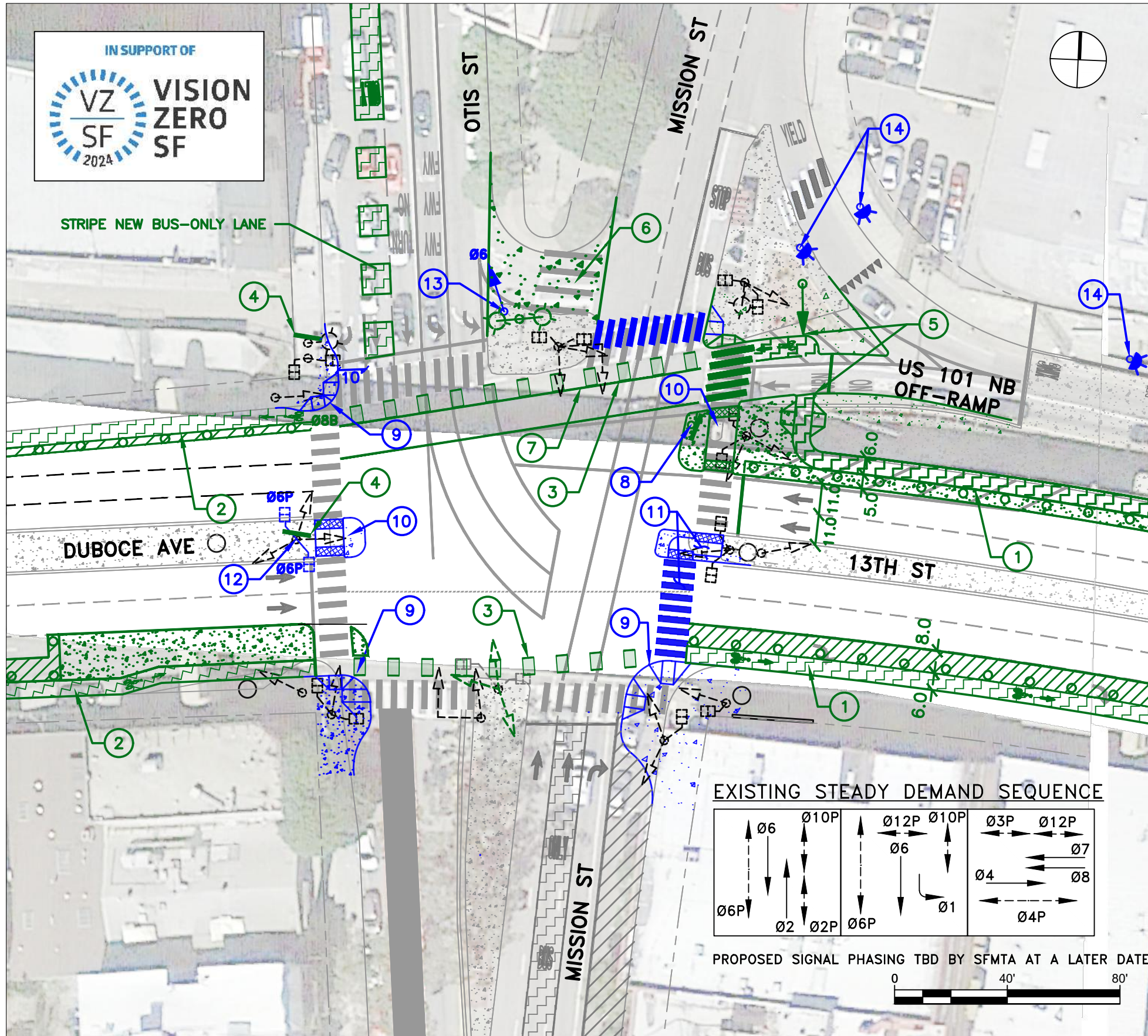

MARKET STREET HUB PROJECT**

EXPECTED COMPLETION 2023

- ① CONSTRUCT PROTECTED CYCLE TRACK ON 13TH STREET. PROTECT WITH DELINEATORS AND CONSIDER FUTURE PLANTER BOXES. REQUIRES REMOVING PORTION OF DUBOCE AVENUE MEDIAN OF MISSION
- ② CONSTRUCT PROTECTED CYCLE TRACK ON DUBOCE AVENUE.
- ③ STRIPE GREEN BIKE CROSSING
- ④ INSTALL "NO RIGHT TURN ON RED" SIGN
- ⑤ CONSTRUCT WB CYCLE TRACK CHANNEL AND INSTALL BICYCLE SIGNAL TO CONTROL THE CROSSING AT THE US 101 OFF-RAMP. REALIGN THE US 101 NB OFF-RAMP APPROACH
- ⑥ CONSTRUCT SIDEWALK
- ⑦ STRIPE OFF-RAMP LANE LINE EXTENSIONS THROUGH THE INTERSECTION

RECOMMENDED IMPROVEMENTS (CAPITAL PROJECT)

- ⑧ INSTALL "NO RIGHT TURN" SIGN
- ⑨ CONSTRUCT BULB-OUT AND CURB RAMPS
- ⑩ CONSTRUCT NEW PEDESTRIAN REFUGE
- ⑪ CONSTRUCT STAGGERED PEDESTRIAN CROSSING AND NEW REFUGE. REALIGN PEDESTRIAN SIGNAL HEADS TO FACILITATE STAGGERED CROSSING
- ⑫ INSTALL PEDESTRIAN SIGNALS AT PEDESTRIAN REFUGE
- ⑬ INSTALL NEARSIDE LEFT TURN SIGNAL HEAD
- ⑭ INSTALL RECTANGULAR RAPID FLASHING BEACON ASSEMBLY

GENERAL: INSTALL APS FOR ALL CROSSINGS

GENERAL: STUDY DAY/NIGHT LIGHTING CONDITIONS UNDER THE FREEWAY STRUCTURE

*NO TURN ON RED

**INCLUDES VISION ZERO RECOMMENDATIONS FOR MARKET STREET HUB PROJECT

***NOTE: ADDITIONAL HUB PROJECT RECOMMENDATIONS MAY BE INCORPORATED INTO FUTURE VERSIONS OF THIS PLAN

MISSION STREET/13TH STREET/US 101 NB OFF-RAMP***

VISION ZERO PHASE 2 RAMP INTERSECTION IMPROVEMENTS

FEBRUARY 2019

MARKET STREET HUB PROJECT (NB OTIS ST ALTERNATIVE)**
EXPECTED COMPLETION 2023

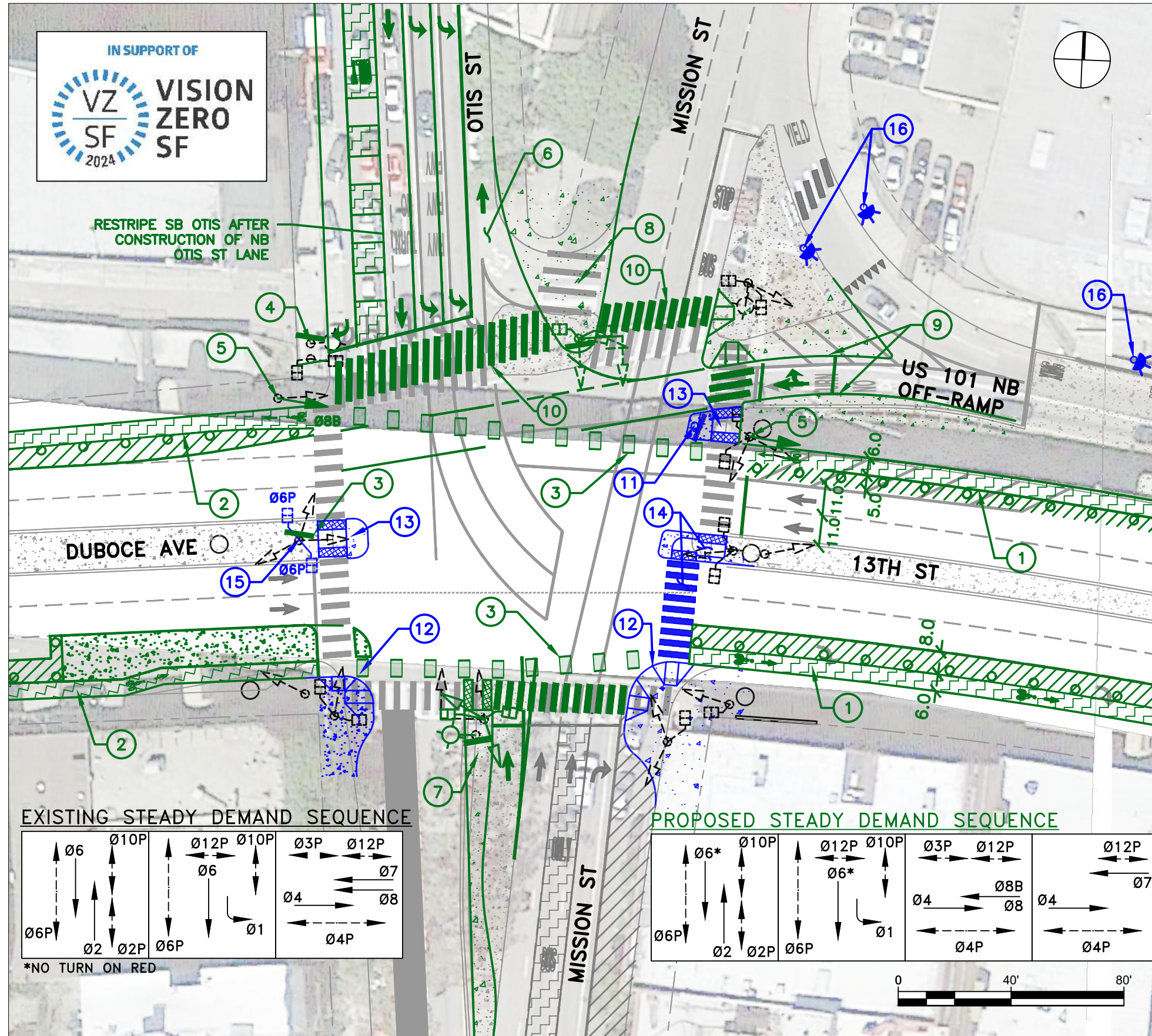

- ① CONSTRUCT PROTECTED CYCLE TRACK ON 13TH STREET. PROTECT WITH DELINEATORS AND CONSIDER FUTURE PLANTER BOXES
- ② CONSTRUCT PROTECTED CYCLE TRACK ON DUBOCE AVENUE
- ③ STRIPE GREEN BIKE CROSSING
- ④ INSTALL "NO RIGHT TURN ON RED" SIGN
- ⑤ INSTALL BIKE SIGNAL. ASSIGN WB BIKE SIGNAL TO Ø8 AND SEPARATE WB Ø8 APPROACH AND US 101 NB OFF-RAMP Ø7 PHASES. SEE PROPOSED STEADY DEMAND SEQUENCE BELOW
- ⑥ CONSTRUCT NB OTIS ST LANE THROUGH PARKING REMOVAL AND SHIFTING OF SB OTIS ST LANES
- ⑦ CONSTRUCT NB OTIS ST LANE BY MODIFYING THE EXISTING MEDIAN. RELOCATE ALL EXISTING CONFLICTING SIGNAL EQUIPMENT
- ⑧ RECONSTRUCT MEDIAN TO ALLOW SPACE FOR RIGHT TURNS ONTO NB OTIS FROM US 101 OFF-RAMP. RELOCATE ALL EXISTING CONFLICTING SIGNAL EQUIPMENT
- ⑨ REALIGN US 101 OFF-RAMP APPROACH AT INTERSECTION AFTER CONSTRUCTION OF WB CYCLE TRACK ON 13TH ST. STRIPE OFF-RAMP LANE LINE EXTENSIONS.
- ⑩ RESTRIPE AND REALIGN HIGH-VISIBILITY CROSSWALK AFTER MEDIAN MODIFICATIONS

RECOMMENDED IMPROVEMENTS (CAPITAL PROJECT)

- ⑪ INSTALL "NO RIGHT TURN" SIGN
- ⑫ CONSTRUCT BULB-OUT AND CURB RAMPS
- ⑬ CONSTRUCT NEW PEDESTRIAN REFUGE
- ⑭ CONSTRUCT STAGGERED PEDESTRIAN CROSSING AND NEW REFUGE. REALIGN PEDESTRIAN SIGNAL HEADS TO FACILITATE STAGGERED CROSSING
- ⑮ INSTALL PEDESTRIAN SIGNALS AT PEDESTRIAN REFUGE
- ⑯ INSTALL RECTANGULAR RAPID FLASHING BEACON ASSEMBLY

GENERAL: INSTALL APS FOR ALL CROSSINGS

GENERAL: STUDY DAY/NIGHT LIGHTING CONDITIONS UNDER THE FREEWAY STRUCTURE

GENERAL: BUS ONLY LANE REQUIRES FURTHER STUDY

****INCLUDES VISION ZERO RECOMMENDATIONS FOR MARKET STREET HUB PROJECT**

*****NOTE: ADDITIONAL HUB PROJECT RECOMMENDATIONS MAY BE INCORPORATED INTO FUTURE VERSIONS OF THIS PLAN**

MISSION STREET/13TH STREET/US 101 NB OFF-RAMP***

VISION ZERO PHASE 2 RAMP INTERSECTION IMPROVEMENTS
 FEBRUARY 2019

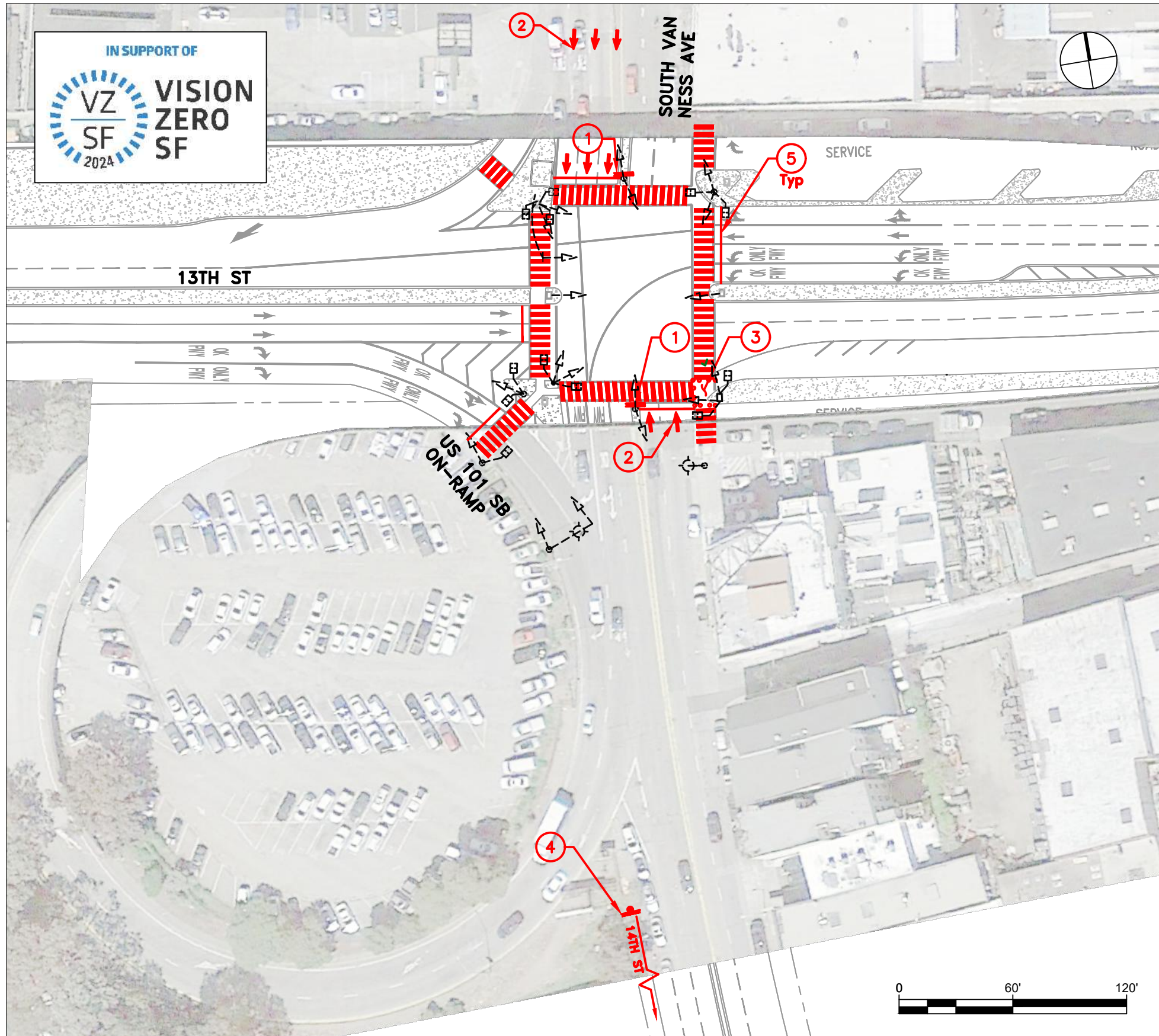

RECOMMENDED IMPROVEMENTS (NEAR-TERM)

- ① INSTALL "NO LEFT TURN" SIGN TO PROHIBIT SOUTHBOUND LEFT TURN MOVEMENTS AT ALL TIMES. CONSIDER LAGGING PROTECTED LEFT TURN AS AN ALTERNATIVE (CAPITAL IMPROVEMENT)
- ② STRIPE THROUGH ARROWS FOR NORTHBOUND AND SOUTHBOUND TO REINFORCE LEFT TURN PROHIBITIONS. NORTHBOUND LEFT TURNS ARE CURRENTLY PROHIBITED.
- ③ CREATE PEDESTRIAN REFUGE AREA USING TEMPORARY MATERIALS (E.G. DELINEATORS AND PAINT) FOR NEAR-TERM IMPLEMENTATION
- ④ INSTALL "SIDEWALK CLOSED AHEAD, CROSS HERE" SIGN AT THE NORTHWEST CORNER OF 14TH STREET AND SOUTH VAN NESS AVE
- ⑤ STRIPE ADVANCE STOP BAR

GENERAL: STRIPE HIGH-VISIBILITY CROSSWALK

GENERAL: INSTALL LEADING PEDESTRIAN INTERVAL FOR CROSSINGS

SOUTH VAN NESS AVE/13TH ST/US 101 SB ON-RAMP

VISION ZERO PHASE 2 RAMP INTERSECTION IMPROVEMENTS

FEBRUARY 2019

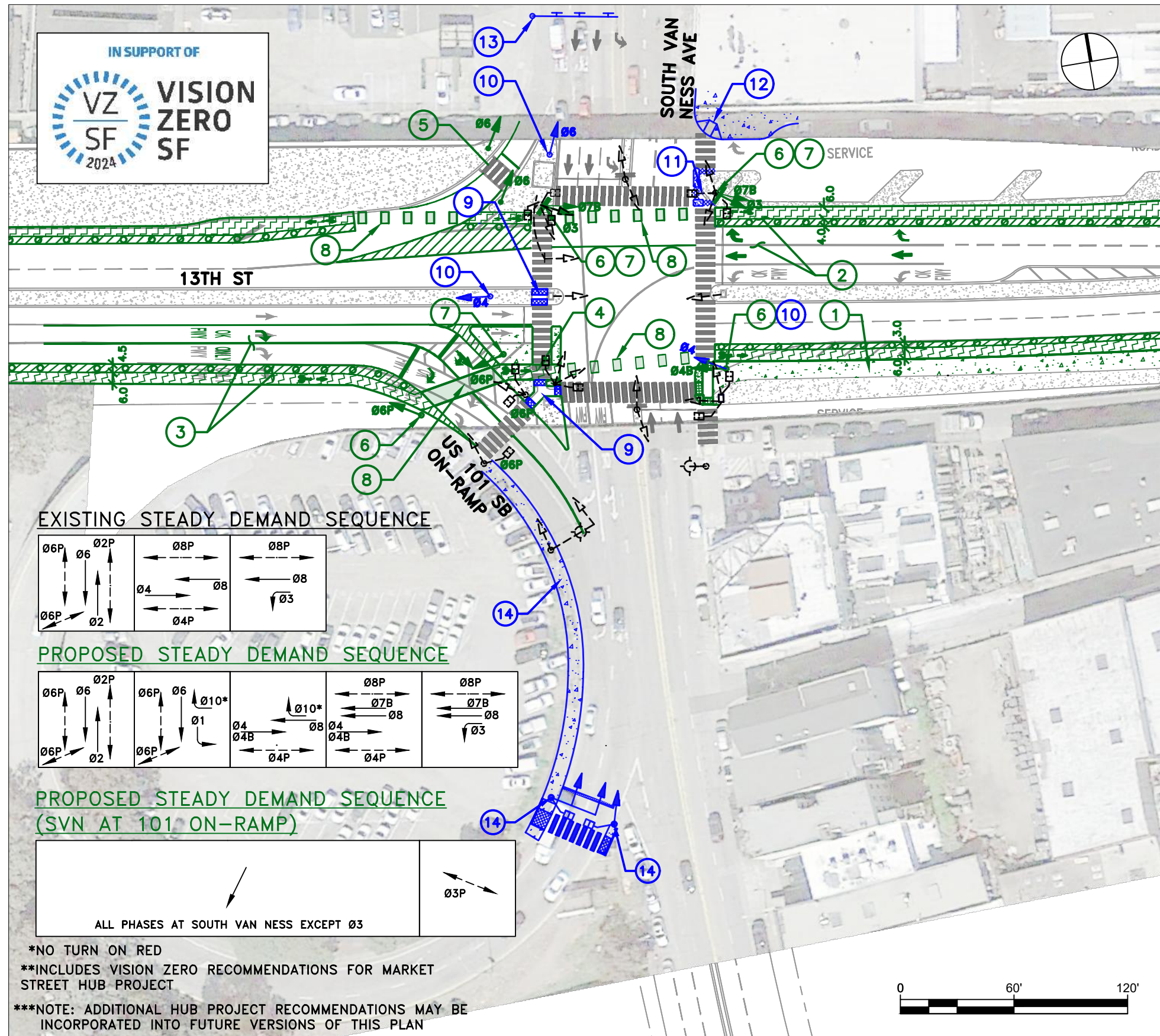

MARKET STREET HUB PROJECT**

EXPECTED COMPLETION 2023

- ① CONSTRUCT MEDIAN EXTENSION
- ② RECONFIGURE LANES BY CONVERTING #2 LANE TO "THROUGH ONLY" LANE, #3 LANE TO "RIGHT TURN ONLY" LANE, AND REMOVE EXISTING #4 LANE. DESIGNATE RIGHT TURN AS "NO TURN ON RED". CONSTRUCT WB PROTECTED CYCLE TRACK ON 13TH STREET. PROTECT WITH DELINEATORS AND CONSIDER FUTURE PLANTER BOXES. OPTION SHOWN STILL UNDER STUDY
- ③ REMOVE EXISTING #2 THROUGH LANE, SHIFT SLIP LANES, AND CHANGE LANE ASSIGNMENTS (AS SHOWN ON PLANS) AND CONSTRUCT EASTBOUND PROTECTED CYCLE TRACK. PROTECT WITH DELINEATORS AND CONSIDER FUTURE PLANTER BOXES
- ④ RECONSTRUCT PORKCHOP ISLAND TO PROVIDE BICYCLE REFUGE AND A WIDER PASSAGEWAY FOR PEDESTRIAN ACCESS
- ⑤ SIGNALIZE SLIP LANE AND ASSIGN SIGNALS TO Ø6. MODIFY EDGELINE STRIPING AND STRIPE STOP BAR
- ⑥ INSTALL BIKE SIGNAL. ASSIGN WESTBOUND BIKE SIGNAL TO Ø7 AND EASTBOUND BIKE SIGNAL TO Ø4
- ⑦ INSTALL RIGHT TURN SIGNAL AND "NO TURN ON RED" SIGN. ASSIGN SIGNAL TO Ø3 TO SEPARATE RIGHT TURN PHASE FROM BIKE PHASE
- ⑧ STRIPE GREEN BIKE CROSSING

RECOMMENDED IMPROVEMENTS (CAPITAL PROJECT)

EXPECTED COMPLETION 2023

- ⑨ UPGRADE PEDESTRIAN PASSAGEWAY WITH DETECTIBLE WARNING SURFACES
- ⑩ INSTALL NEW TRAFFIC SIGNAL
- ⑪ CONSTRUCT PEDESTRIAN REFUGE
- ⑫ CONSTRUCT BULB-OUT AND CURB RAMP
- ⑬ INSTALL OVERHEAD LANE ASSIGNMENT SIGN
- ⑭ EXTEND SIDEWALK TOWARDS US 101 SB ON-RAMP AND INSTALL NEW SIGNAL. MAY REQUIRE RELOCATION OF EXISTING SIGNAL POLES.

GENERAL: UPGRADE ALL 8" SIGNAL HEADS TO 12"

GENERAL: INSTALL 12" SECTION BACKPLATES FOR ALL SIGNAL HEADS

GENERAL: INSTALL APS

GENERAL: STUDY PROVIDING DAYTIME LIGHTING UNDER THE BRIDGE
 GENERAL: HUB STUDY WILL BE ADDING FRONTAGE ROAD ISLANDS ON SOUTH VAN NESS NORTH OF THIS INTERSECTION. (DOES NOT AFFECT DRAWING SHOWN)

SOUTH VAN NESS AVE/13TH ST/US 101 SB ON-RAMP***

VISION ZERO PHASE 2 RAMP INTERSECTION IMPROVEMENTS

FEBRUARY 2019

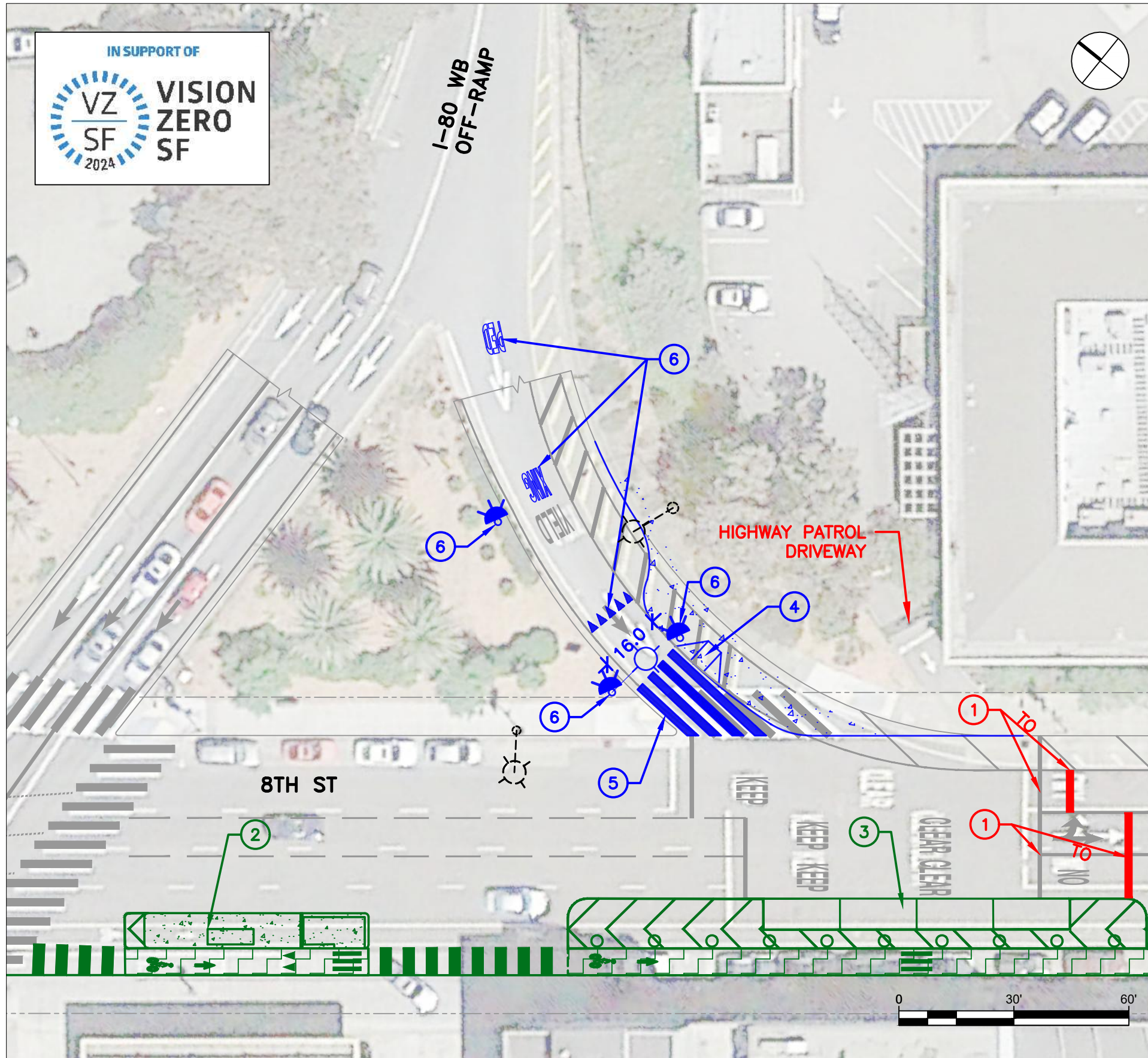

RECOMMENDED IMPROVEMENTS (NEAR-TERM)

- ① EXTEND FAR SIDE BOUNDARY LINE OF EXISTING "KEEP CLEAR" ZONE TO PREVENT BLOCKAGE OF HIGHWAY PATROL ACCESS

SFMTA 8TH STREET SAFETY PROJECT

- ② TRANSIT BOARDING ISLAND WITH ADA CURB RAMP AND CROSSWALK IMPLEMENTED LATE 2018
- ③ PARKING-PROTECTED BIKE LANE AND STRIPING MODIFICATIONS IMPLEMENTED MID 2018

RECOMMENDED IMPROVEMENTS (CAPITAL PROJECT)

- ④ CONSTRUCT BULB-OUT AND CURB RAMP
- ⑤ REMOVE EXISTING PAVEMENT MARKINGS, STRIPE YIELD LINE AND "PED XING" PAVEMENT MARKINGS, RE-ORIENT HIGH-VISIBILITY CROSSWALK
- ⑥ INSTALL RECTANGULAR RAPID FLASHING BEACON ASSEMBLY AND STUDY ADDITIONAL STREETLIGHTING

8TH STREET (MIDBLOCK)/I-80 WB OFF-RAMP

VISION ZERO PHASE 2 RAMP INTERSECTION IMPROVEMENTS

FEBRUARY 2019

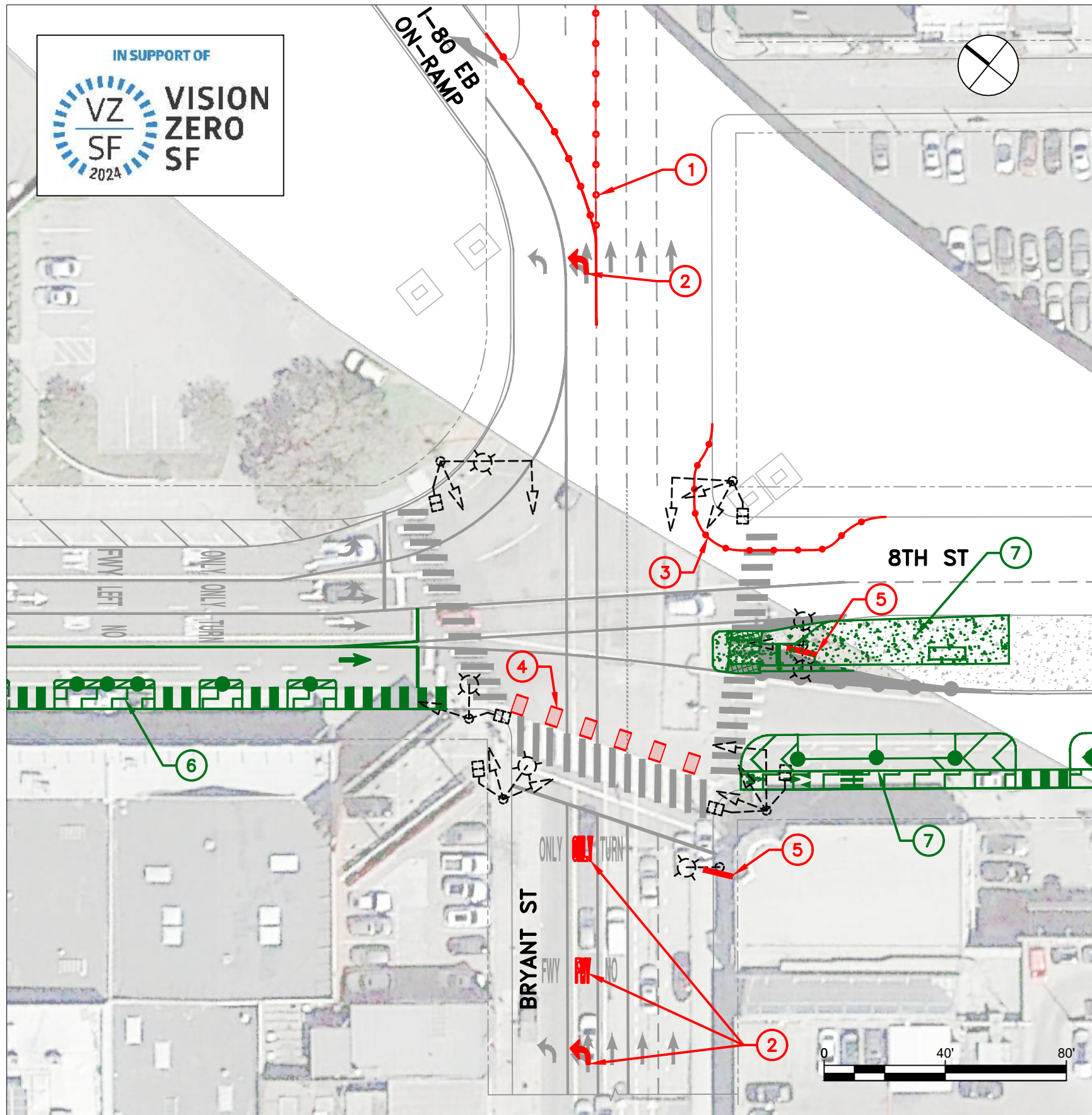

RECOMMENDED IMPROVEMENTS (NEAR-TERM)

- ① STRIPE AND INSTALL DELINEATORS TO CHANNELIZE ON-RAMP TRAFFIC
- ② CONVERT #2 LANE TO "FREEWAY ONLY" LANE
- ③ INSTALL BULB-OUT USING TEMPORARY MATERIALS (E.G. DELINEATORS AND PAINT) FOR NEAR-TERM IMPLEMENTATION
- ④ STRIPE GREEN BIKE CROSSING AFTER IMPLEMENTATION OF SFMTA 8TH STREET SAFETY PROJECT PHASE 2
- ⑤ INSTALL "NO TURN ON RED" SIGN

GENERAL: INSTALL LEADING PEDESTRIAN INTERVAL FOR CROSSING

SFMTA PROJECT 8TH STREET SAFETY PROJECT

- ⑥ PROTECTED BIKE LANE AND STRIPING MODIFICATIONS IMPLEMENTED 2018
- ⑦ NEW TRANSIT BOARDING ISLAND AND CORRESPONDING EXPANDED EXTENT OF PROTECTED BIKE LANES TO BE IMPLEMENTED 2020

BRYANT STREET/8TH STREET/I-80 EB ON-RAMP

VISION ZERO PHASE 2 RAMP INTERSECTION IMPROVEMENTS

FEBRUARY 2019

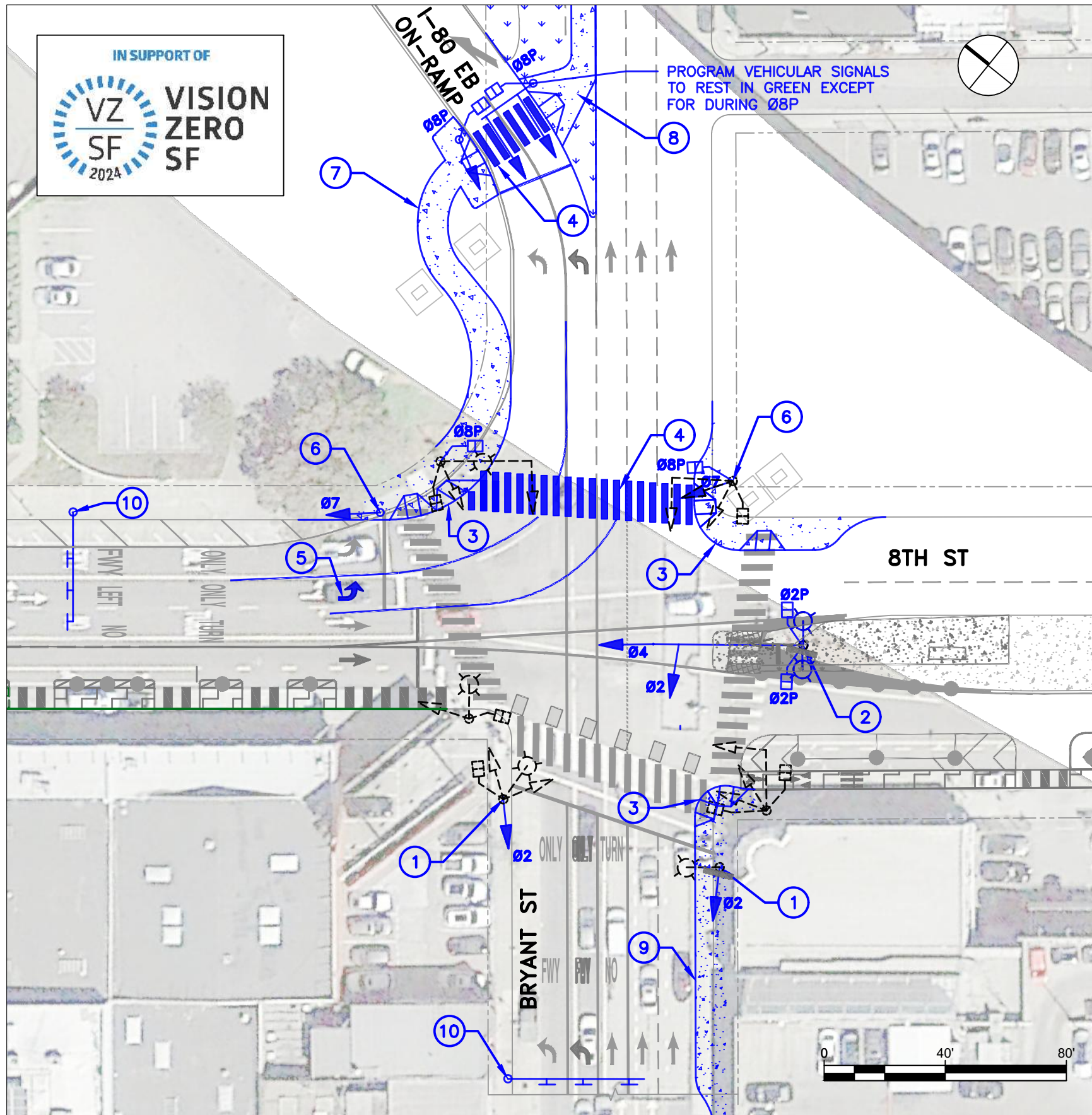

RECOMMENDED IMPROVEMENTS (CAPITAL PROJECT)

- ① INSTALL NEARSIDE TRAFFIC SIGNAL
- ② UPGRADE TO MAST ARM POLE AND INSTALL PEDESTRIAN SIGNALS.
- ③ CONSTRUCT BULB-OUT AND CURB RAMPS. STRIPE LEFT-TURN GUIDING LINES
- ④ STRIPE AND SIGNALIZE NEW PEDESTRIAN CROSSING AND ASSIGN TO Ø8P. SEE PROPOSED STEADY DEMAND SEQUENCE BELOW
- ⑤ CONVERT #2 LANE TO "LEFT TURN ONLY" LANE
- ⑥ PROVIDE PROTECTED PHASING OF LEFT TURNS FROM 8TH STREET (Ø7) AND INSTALL LEFT TURN SIGNALS. SEE PROPOSED STEADY DEMAND SEQUENCE BELOW
- ⑦ EXTEND SIDEWALK TO I-80 ON-RAMP
- ⑧ CONSTRUCT CURB EXTENSION WITH SIDEWALK AND LANDSCAPING
- ⑨ CONSTRUCT BUS BULB
- ⑩ INSTALL OVERHEAD LANE ASSIGNMENT SIGNS

GENERAL: INSTALL APS FOR ALL CROSSINGS

EXISTING STEADY DEMAND SEQUENCE

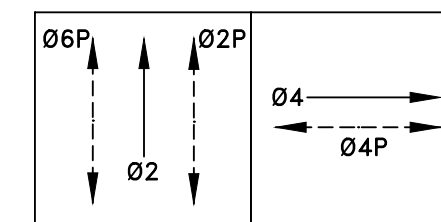

PROPOSED STEADY DEMAND SEQUENCE

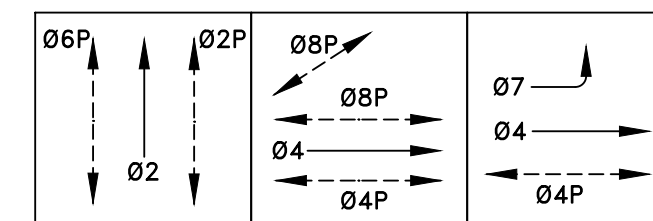

BRYANT STREET/8TH STREET/I-80 EB ON-RAMP

VISION ZERO PHASE 2 RAMP INTERSECTION IMPROVEMENTS

FEBRUARY 2019

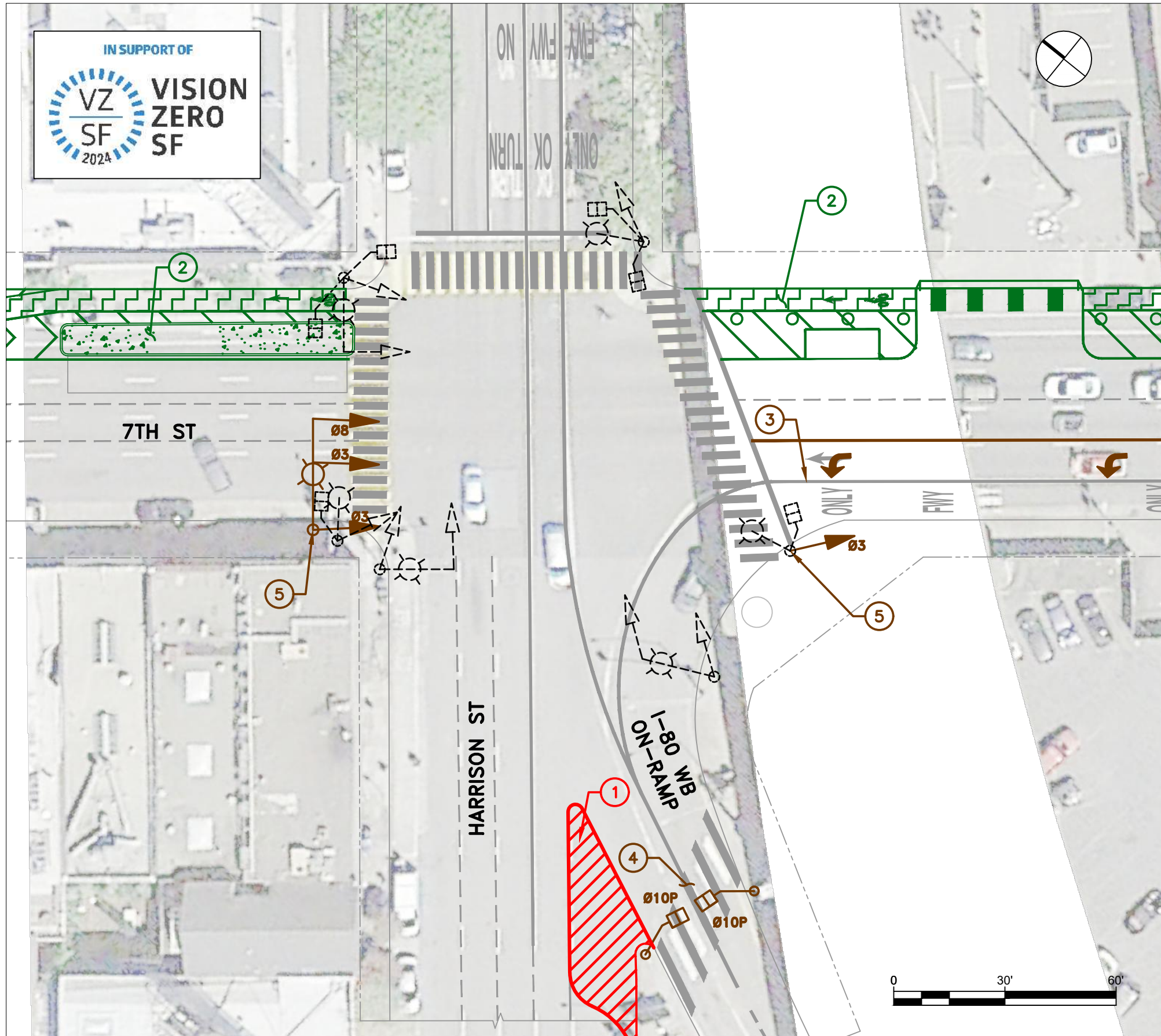

RECOMMENDED IMPROVEMENTS (NEAR-TERM)

- ① STRIPE CROSSHATCH PAVEMENT MARKINGS TO IMPROVE ON-RAMP CHANNELIZATION

SFMTA 7TH STREET NEAR-TERM SAFETY PROJECT ITEMS UNDER STUDY FOR IMPLEMENTATION 2020

- ② PARKING-PROTECTED BIKE LANE AND TRANSIT BOARDING ISLAND

CALTRANS PROJECT WITH IMPLEMENTATION IN EARLY 2019

- ③ CONVERSION OF #1 AND #2 LANES INTO TWO PROTECTED LEFT-TURN LANES. ASSIGN TO Ø3. SEE PROPOSED STEADY DEMAND SEQUENCE BELOW
- ④ SIGNALIZATION OF ON-RAMP PEDESTRIAN CROSSING. ASSIGN TO Ø10P. SEE PROPOSED STEADY DEMAND SEQUENCE BELOW
- ⑤ INSTALLATION OF NEW TRAFFIC SIGNAL EQUIPMENT. EXISTING SIGNALS TO BE REMOVED

EXISTING STEADY DEMAND SEQUENCE

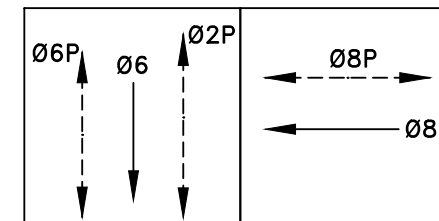

PROPOSED STEADY DEMAND SEQUENCE

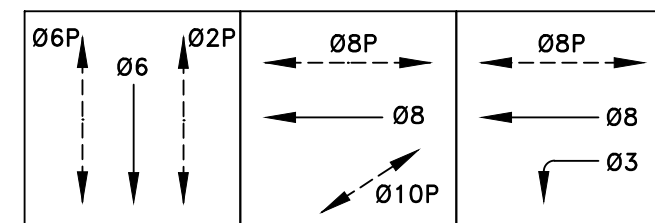

HARRISON STREET/7TH STREET/I-80 WB ON-RAMP
 VISION ZERO PHASE 2 RAMP INTERSECTION IMPROVEMENTS
 FEBRUARY 2019

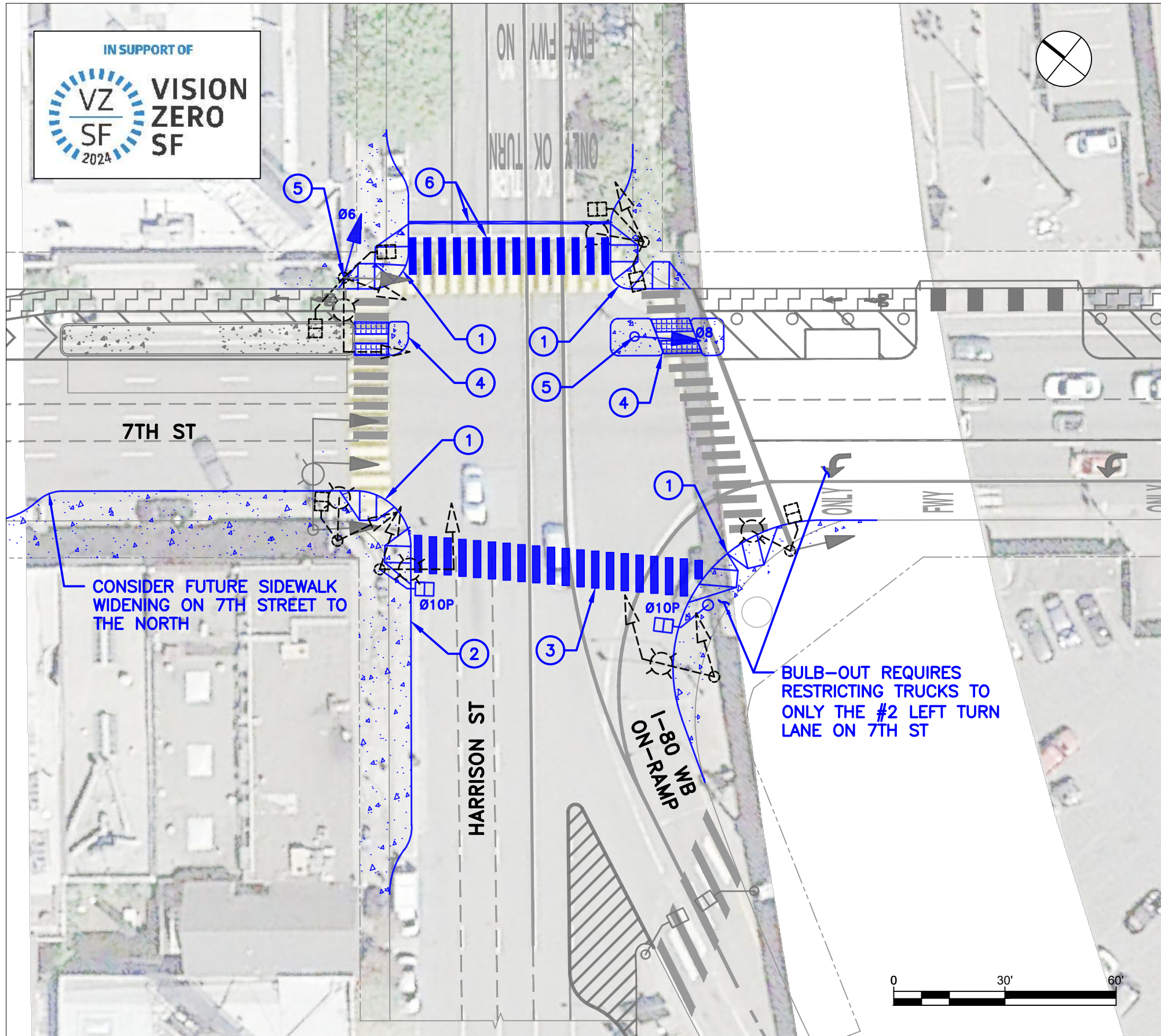

RECOMMENDED IMPROVEMENTS (CAPITAL PROJECT)

- ① CONSTRUCT BULB-OUT AND CURB RAMPS
- ② CONSTRUCT BUS-BULB CURB EXTENSION
- ③ STRIPE AND SIGNALIZE NEW PEDESTRIAN CROSSING AND ASSIGN TO Ø10P. SEE PROPOSED STEADY DEMAND SEQUENCE BELOW
- ④ CONSTRUCT PEDESTRIAN REFUGE
- ⑤ INSTALL NEAR-SIDE TRAFFIC SIGNAL
- ⑥ REALIGN CROSSWALK AND STRIPE ADVANCE STOP BAR

GENERAL: INSTALL APS FOR ALL CROSSINGS

GENERAL NOTES

1140 HARRISON STREET PROJECT JUST WEST OF THE ON-RAMP (NEW DEVELOPMENT) WILL WIDEN HARRISON STREET'S NORTH SIDEWALK FROM BERWICK TO LANGTON FROM 8 TO 15 FEET. PARKING WILL BE RETAINED. SPACE IS COMING FROM A LANE REDUCTION. MAY BE ABLE TO CONTINUE THE SIDEWALK WIDENING FROM LANGTON TO 7TH PLUS THE BUS BULB.

PROPOSED STEADY DEMAND SEQUENCE

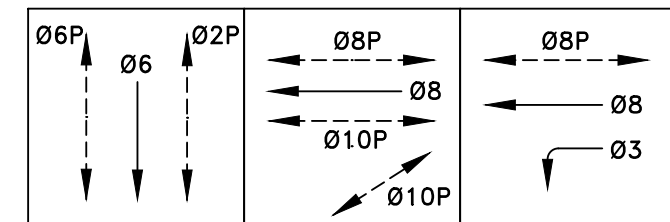

HARRISON STREET/7TH STREET/I-80 WB ON-RAMP

VISION ZERO PHASE 2 RAMP INTERSECTION IMPROVEMENTS

FEBRUARY 2019

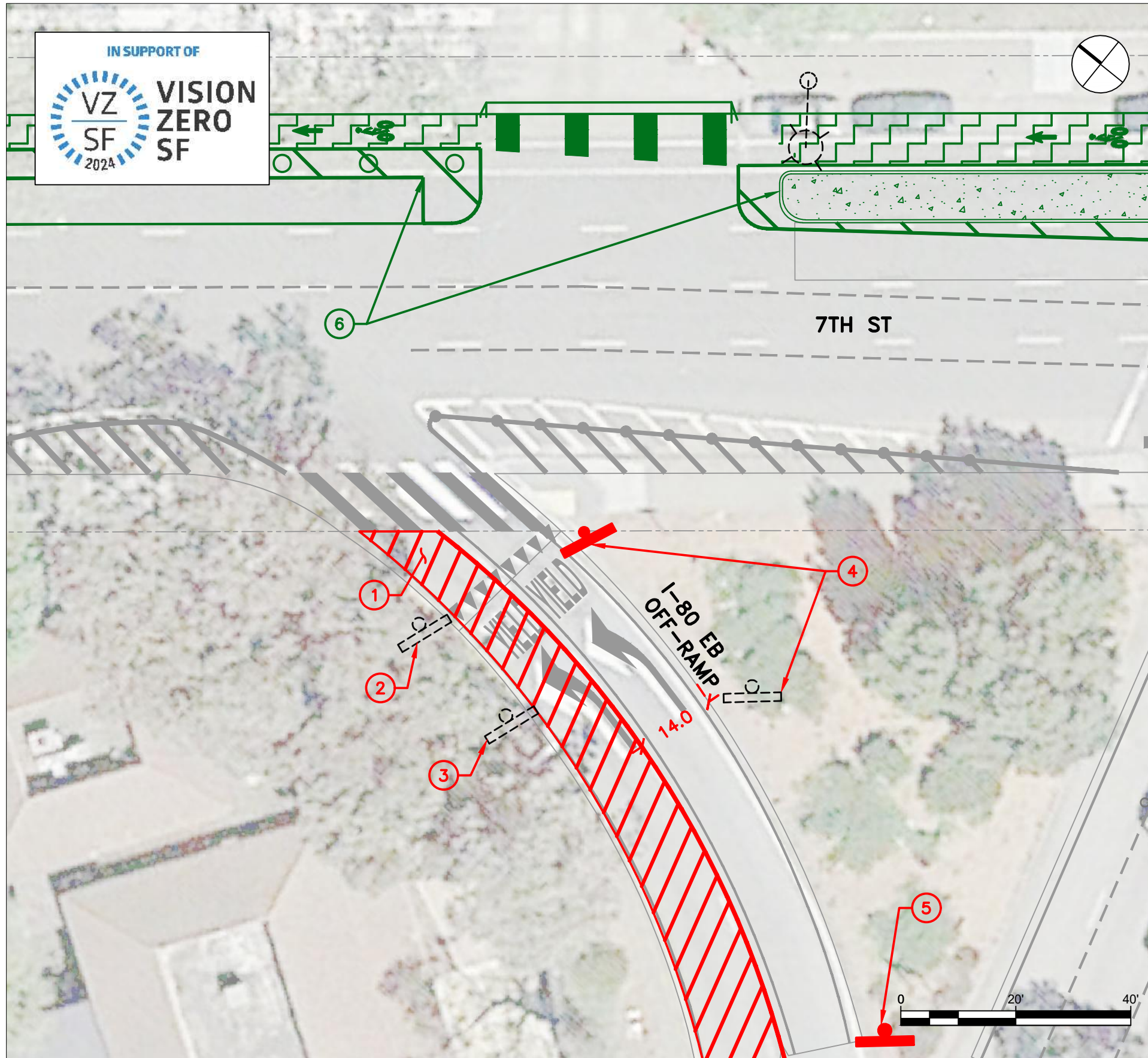

RECOMMENDED IMPROVEMENTS (NEAR-TERM)*

- ① REMOVE #1 LANE AND EXISTING PAVEMENT MARKINGS AND STRIPE CROSSHATCH PAVEMENT MARKINGS
- ② REMOVE EXISTING "YIELD HERE TO PEDESTRIANS" SIGN
- ③ REMOVE EXISTING "YIELD" SIGN
- ④ RELOCATE EXISTING PEDESTRIAN CROSSING SIGN TO CORNER AND INSTALL LEFT DIAGONAL ARROW PLAQUE BELOW EXISTING SIGN
- ⑤ INSTALL "PEDESTRIAN CROSSING AHEAD" WARNING SIGN AND PLAQUE

SFMTA 7TH STREET NEAR-TERM SAFETY PROJECT-

ITEMS UNDER STUDY FOR IMPLEMENTATION IN 2020

- ⑥ PARKING-PROTECTED BIKE PATH AND TRANSIT BOARDING ISLAND

GENERAL NOTES

HALL OF JUSTICE OFF-RAMP REALIGNMENT PROJECT ON HOLD INDEFINITELY

MUNI 8 BAYSHORE MAY BE RE-ROUTED ONTO THIS OFF-RAMP, WHICH WILL AFFECT THE RECOMMENDED DESIGN. MORE INFORMATION TO COME 2020

*ALL ITEMS REQUIRE CALTRANS APPROVAL PROCESS

7TH STREET (MIDBLOCK)/I-80 EB OFF-RAMP

VISION ZERO PHASE 2 RAMP INTERSECTION IMPROVEMENTS

FEBRUARY 2019

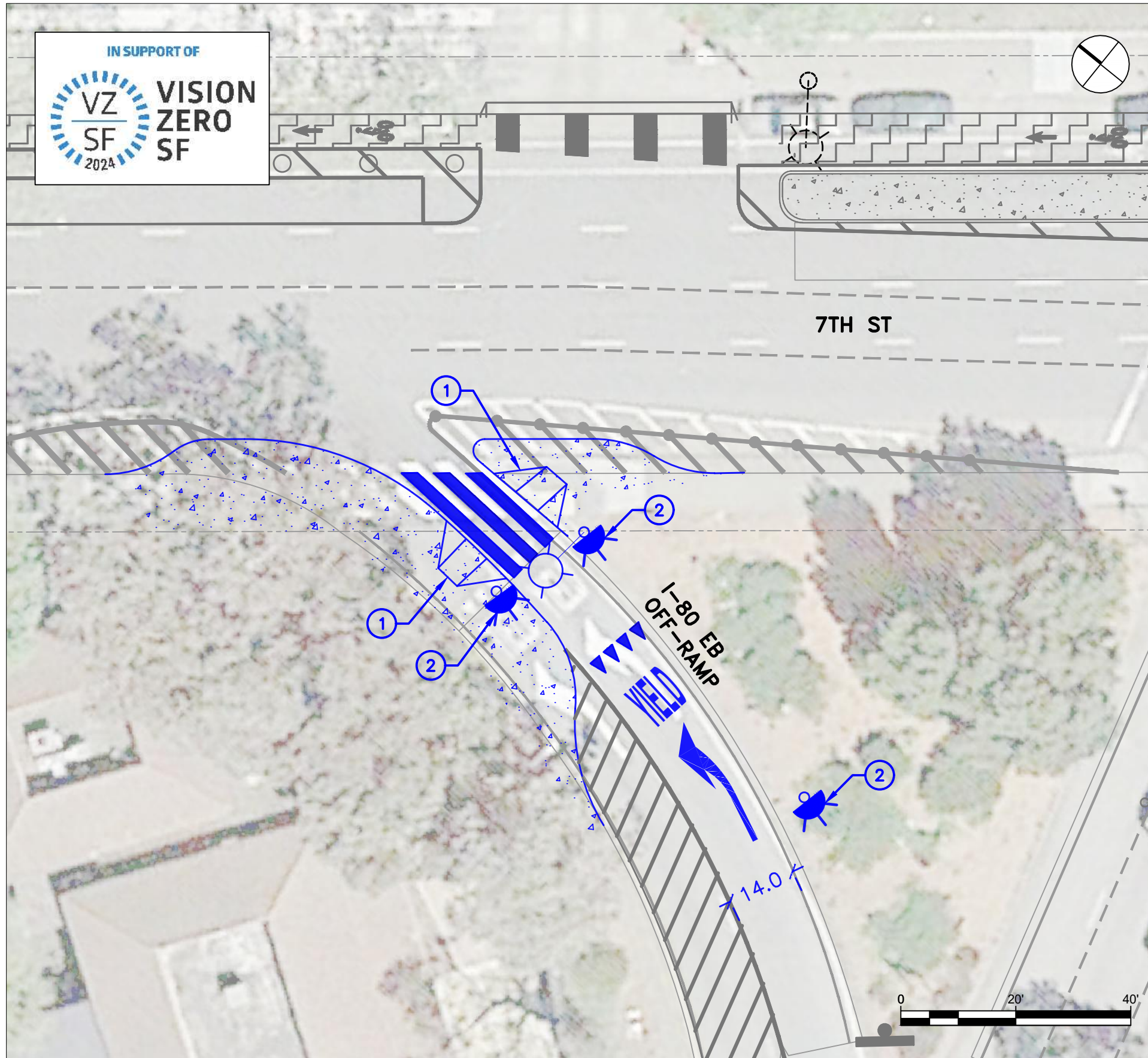

RECOMMENDED IMPROVEMENTS (CAPITAL PROJECT)

- ① CONSTRUCT BULB-OUT AND CURB RAMPS
- ② INSTALL RECTANGULAR RAPID FLASHING BEACON ASSEMBLY AND STUDY ADDITIONAL LIGHTING

GENERAL: STRIPE CONTINENTAL CROSSWALKS

GENERAL: READJUST YIELD LINE, "YIELD", AND LEFT TURN ARROW PAVEMENT MARKINGS

GENERAL NOTES

HALL OF JUSTICE OFF-RAMP REALIGNMENT PROJECT ON HOLD INDEFINITELY

MUNI 8 BAYSHORE MAY BE RE-ROUTED ONTO THIS OFF-RAMP, WHICH WILL AFFECT THE RECOMMENDED DESIGN. MORE INFORMATION TO COME 2020

7TH STREET (MIDBLOCK)/I-80 EB OFF-RAMP

VISION ZERO PHASE 2 RAMP INTERSECTION IMPROVEMENTS

FEBRUARY 2019

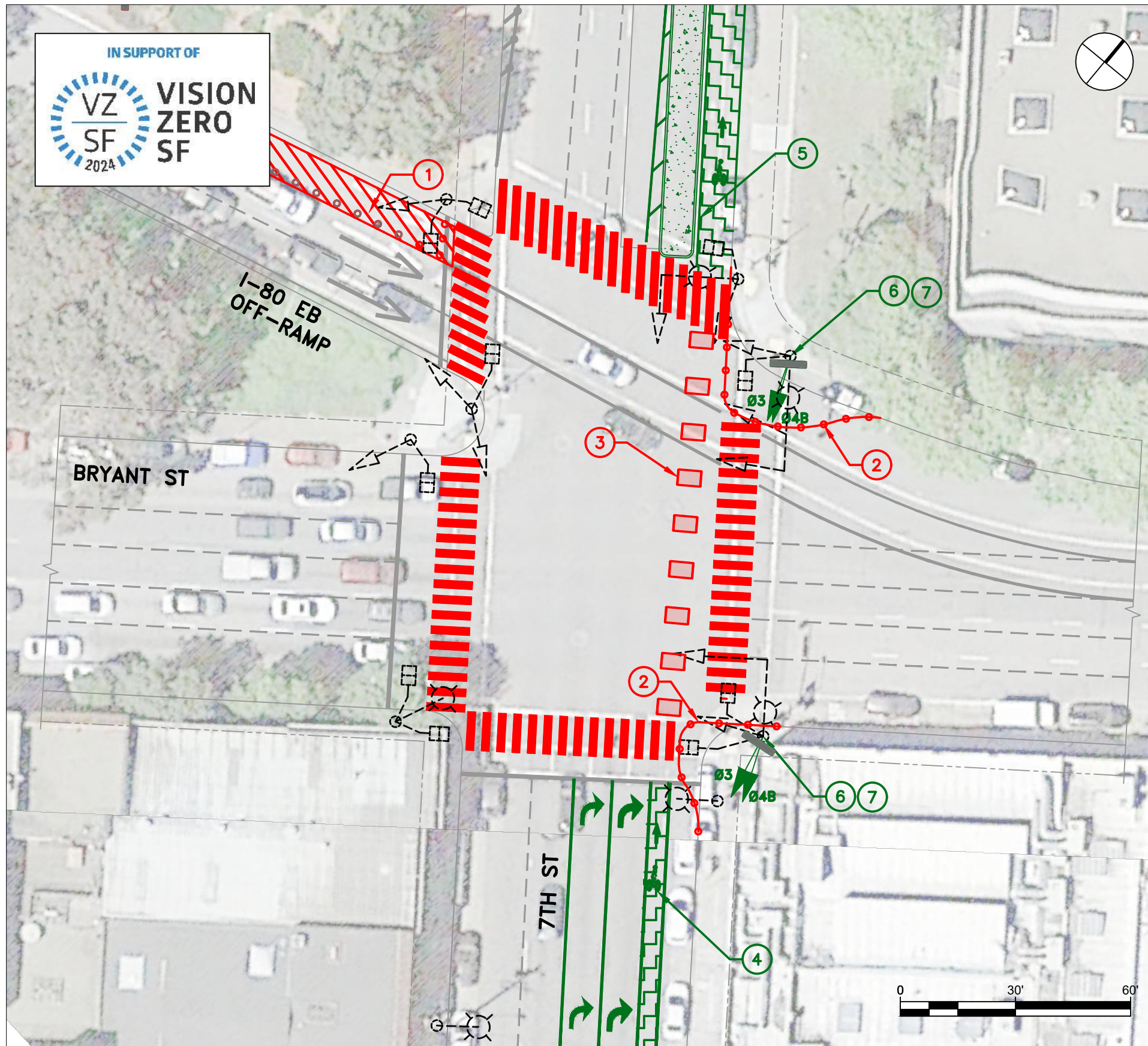

BRYANT STREET/7TH STREET/I-80 EB OFF-RAMP
 VISION ZERO PHASE 2 RAMP INTERSECTION IMPROVEMENTS
 FEBRUARY 2019

RECOMMENDED IMPROVEMENTS (NEAR-TERM)

- ① REMOVE #1 LANE AT OFF-RAMP. INSTALL DELINEATORS AND STRIPE CROSSHATCH PAVEMENT MARKINGS. REQUIRES LENGTHY CALTRANS APPROVAL PROCESS
 - ② INSTALL BULB-OUT USING TEMPORARY MATERIALS (E.G. DELINEATORS AND PAINT) FOR NEAR-TERM IMPLEMENTATION
 - ③ STRIPE GREEN BIKE CROSSING
- GENERAL: STRIPE HIGH-VISIBILITY CROSSWALK

SFMTA 7TH STREET NEAR-TERM SAFETY PROJECT
 ITEMS UNDER STUDY, FOR IMPLEMENTATION IN 2020

- ④ BIKE LANE AND STRIPING. SIGNAL AND PHASING MODIFICATIONS REQUIRED TO STAGE BICYCLISTS TO THE RIGHT OF A "RIGHT TURN ONLY LANE". SIGNAL CHANGES ARE PENDING COORDINATION WITH UPCOMING WATER MAIN WORK ON 7TH STREET. SEE NOTES 5 AND 6 ON THIS SHEET AND THE PROPOSED STEADY DEMAND SEQUENCE BELOW
- ⑤ MEDIAN-PROTECTED CYCLE TRACK
- ⑥ INSTALL BIKE SIGNAL AND "NO TURN ON RED" SIGN. ASSIGN TO Ø4B. SEE PROPOSED STEADY DEMAND SEQUENCE BELOW*
- ⑦ INSTALL RIGHT TURN SIGNAL. ASSIGN TO Ø3 TO LEAD-LAG NB BICYCLE AND RIGHT TURN PHASE RESPECTIVELY. SEE PROPOSED STEADY DEMAND SEQUENCE BELOW*

GENERAL NOTES

HALL OF JUSTICE OFF-RAMP REALIGNMENT PROJECT ON HOLD INDEFINITELY

EXISTING STEADY DEMAND SEQUENCE

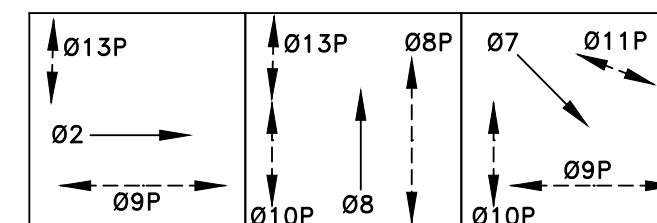

PROPOSED STEADY DEMAND SEQUENCE

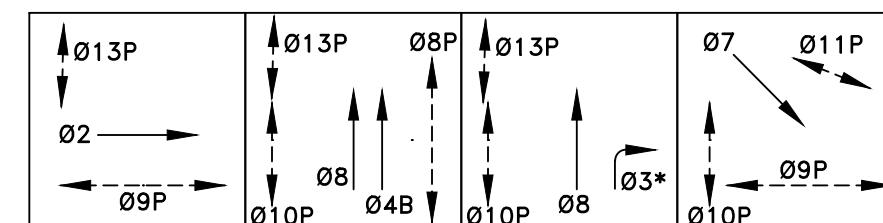

*NO TURN ON RED

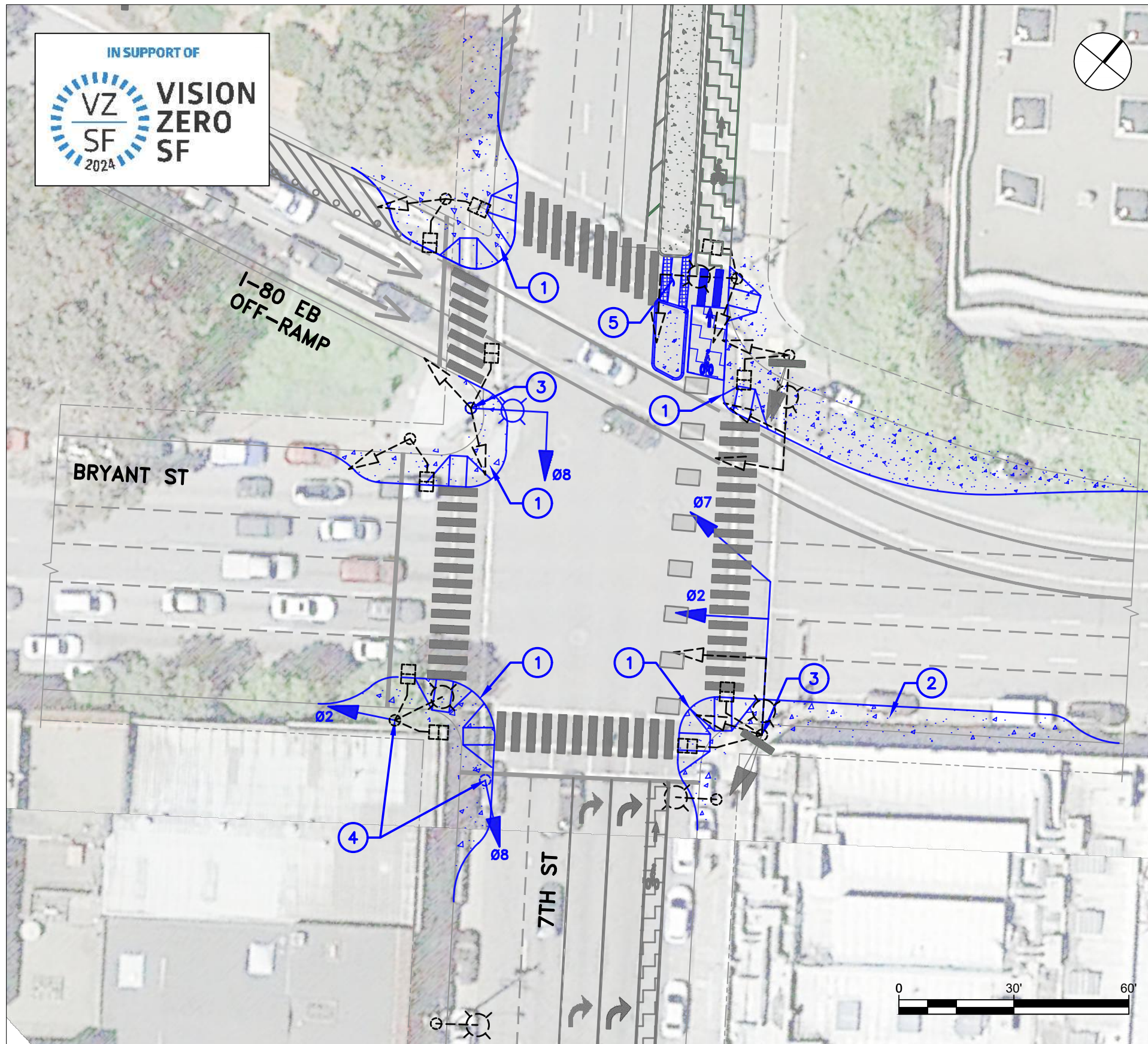

RECOMMENDED IMPROVEMENTS (CAPITAL PROJECT)

- ① CONSTRUCT BULB-OUT AND CURB RAMPS
- ② CONSTRUCT BUS-BULB CURB EXTENSION
- ③ UPGRADE TO MAST ARM POLE
- ④ INSTALL NEARSIDE TRAFFIC SIGNAL
- ⑤ CONSTRUCT PEDESTRIAN REFUGE, STRIPE AND EXTEND MEDIAN-PROTECTED CYCLE TRACK

GENERAL: INSTALL APS FOR ALL CROSSINGS. STUDY STREETLIGHT CONDITIONS AT NORTHWEST CORNER

GENERAL NOTES

HALL OF JUSTICE OFF-RAMP REALIGNMENT PROJECT ON HOLD INDEFINITELY

BRYANT STREET/7TH STREET/I-80 EB OFF-RAMP

VISION ZERO PHASE 2 RAMP INTERSECTION IMPROVEMENTS

FEBRUARY 2019

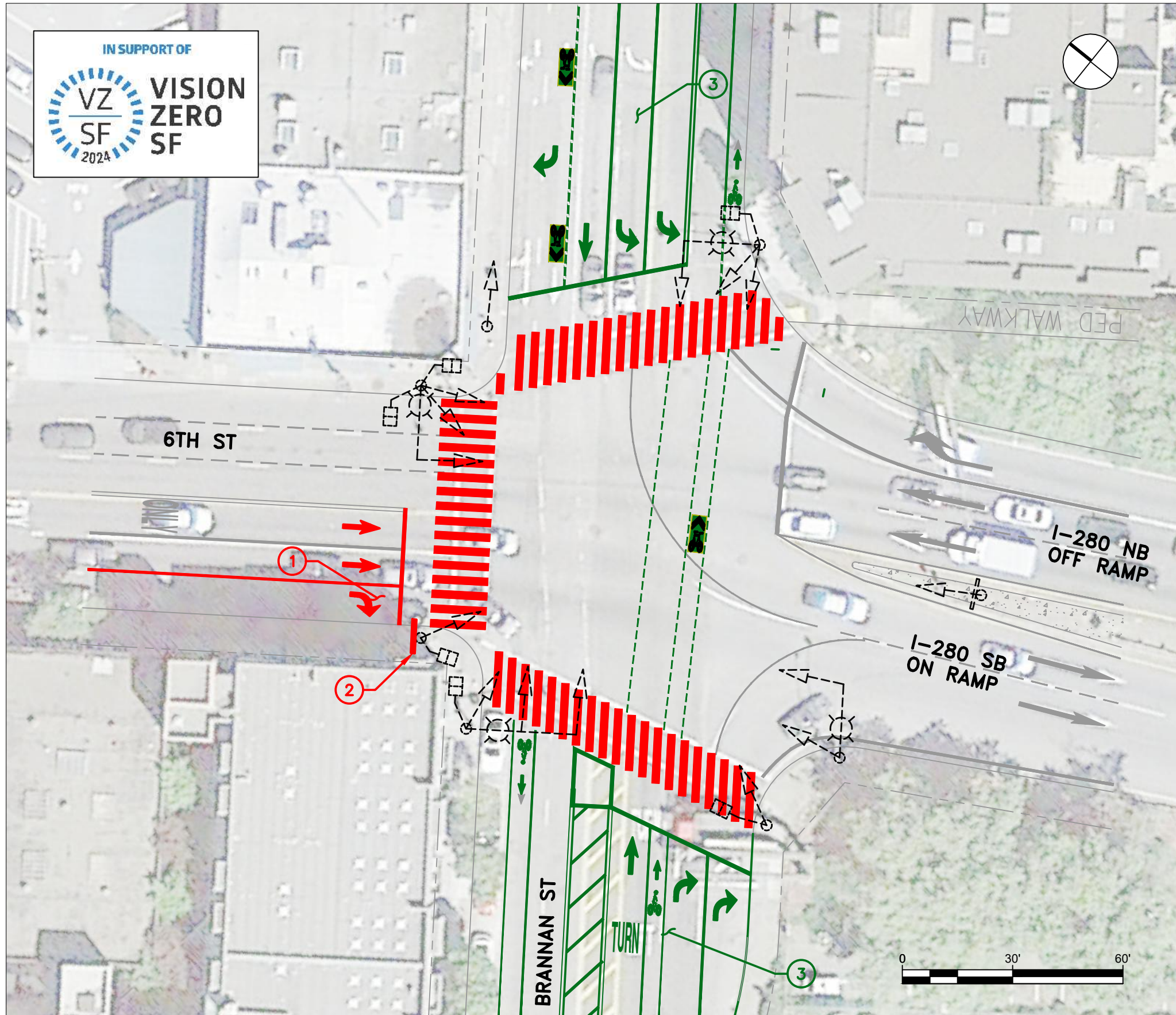

RECOMMENDED IMPROVEMENTS (NEAR-TERM)

- ① CONVERT TOW-AWAY LANE TO "RIGHT TURN ONLY" LANE. PROHIBIT TRUCK RIGHT TURNS NOTE: TRUCKS CAN DRIVE OVER PAINTED MEDIAN
 - ② INSTALL "RIGHT LANE MUST TURN RIGHT" SIGN
- GENERAL: STRIPE HIGH VISIBILITY CROSSWALK
- GENERAL: UPGRADE ALL 8" SIGNAL HEADS TO 12"
- GENERAL: INSTALL 12" SECTION BACKPLATES FOR ALL SIGNAL HEADS
- GENERAL: INSTALL LEADING PEDESTRIAN INTERVAL FOR Ø6P

SFMTA PROJECT

- ③ STRIPING MODIFICATIONS TO BE COMPLETED MID-2019 VIA SFMTA 6TH & BRANNAN ROAD DIET PROJECT

BRANNAN STREET/6TH STREET/I-280 ON/OFF-RAMP

VISION ZERO PHASE 2 RAMP INTERSECTION IMPROVEMENTS
 FEBRUARY 2019

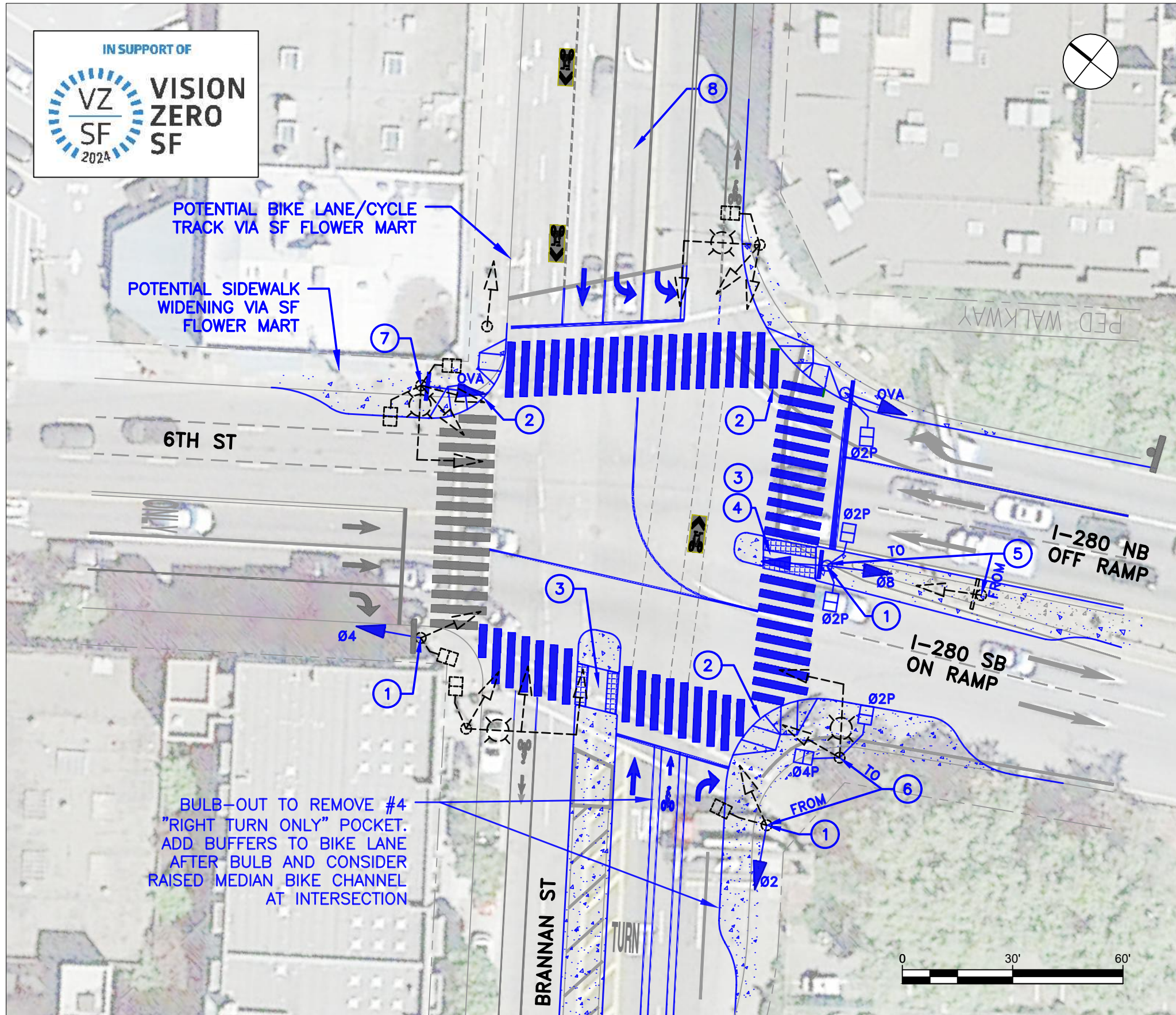

RECOMMENDED IMPROVEMENTS (CAPITAL PROJECT)

- ① INSTALL NEAR SIDE TRAFFIC SIGNAL HEAD
- ② CONSTRUCT BULB-OUT AND CURB RAMPS
- ③ CONSTRUCT RAISED MEDIAN AND PEDESTRIAN REFUGE
- ④ SIGNALIZE NEW PEDESTRIAN CROSSING. ASSIGN PEDESTRIAN SIGNALS TO Ø2P. SEE PROPOSED STEADY DEMAND SEQUENCE BELOW.
- ⑤ RELOCATE EXISTING TRAFFIC SIGNAL ASSEMBLY CLOSER TO THE MIDDLE OF THE INTERSECTION
- ⑥ RELOCATE EB PEDESTRIAN SIGNAL TO MAST ARM SIGNAL POLE TO ALIGN SIGNAL WITH NEW CROSSING
- ⑦ INSTALL RIGHT TURN SIGNAL AND INSTALL "NO TURN ON RED" SIGN. ASSIGN RIGHT TURN SIGNAL PHASE TO OVERLAP PHASE (OVA). SEE PROPOSED STEADY DEMAND SEQUENCE BELOW
- ⑧ RESTRICT TRUCK TURNS TO #2 "LEFT TURN ONLY LANE" WITH SIGNAGE

GENERAL: INSTALL APS FOR ALL CROSSINGS

GENERAL: REALIGN AND RESTRIPE HIGH-VISIBILITY CROSSWALK AND STRIPING AFTER BULB-OUT AND PEDESTRIAN REFUGE CONSTRUCTION

EXISTING STEADY DEMAND SEQUENCE

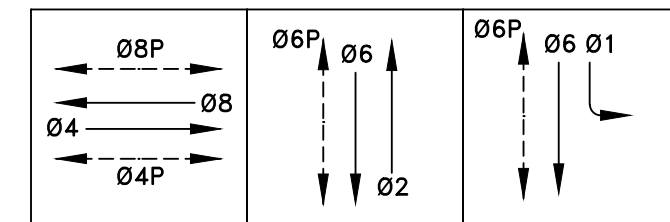

PROPOSED STEADY DEMAND SEQUENCE

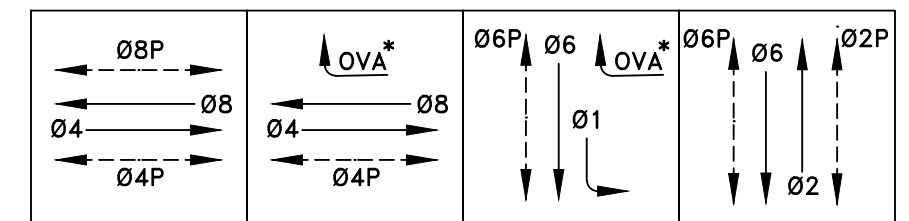

*NO RIGHT TURN ON RED

BRANNAN STREET/6TH STREET/I-280 ON/OFF-RAMP

VISION ZERO PHASE 2 RAMP INTERSECTION IMPROVEMENTS

FEBRUARY 2019

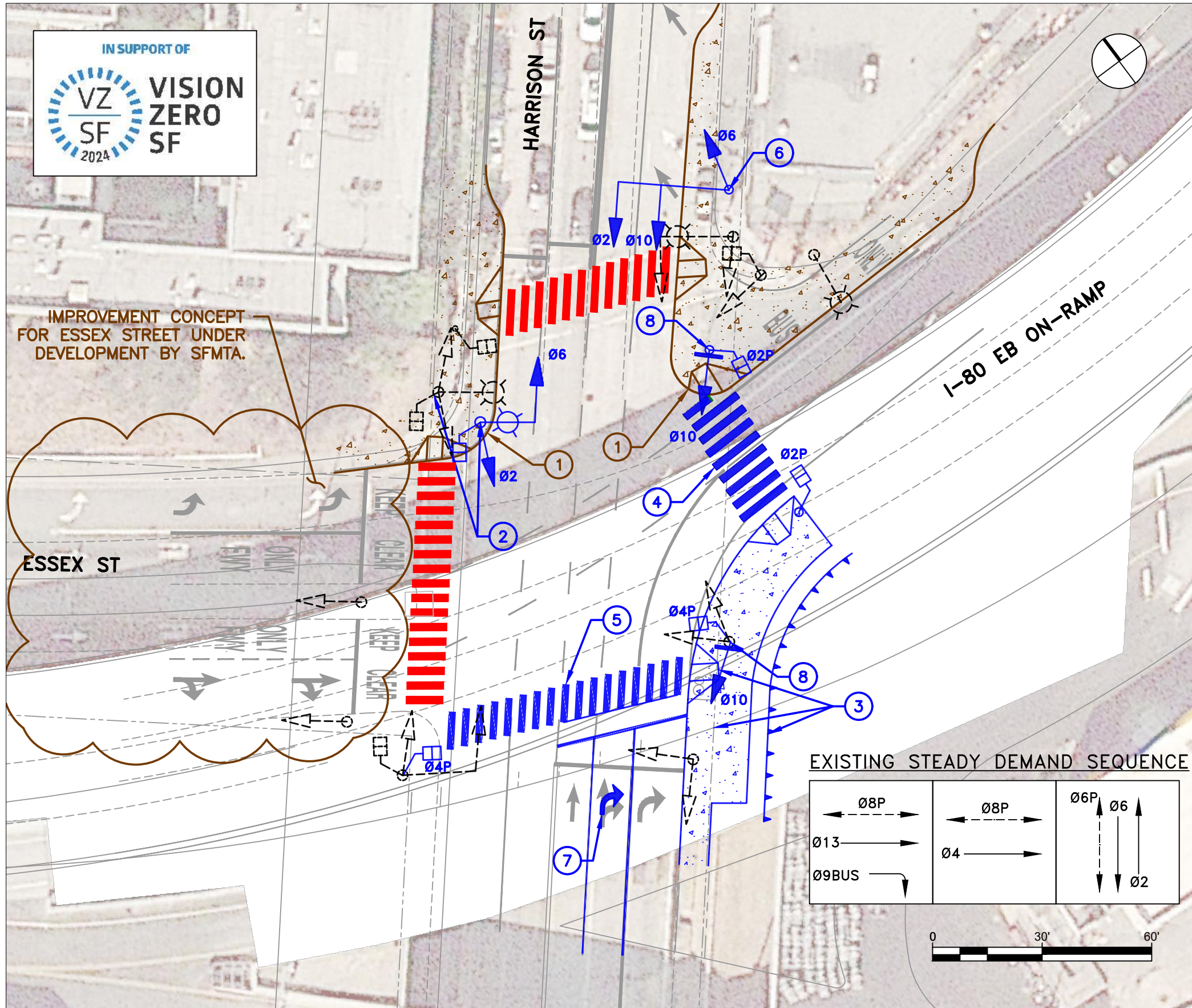
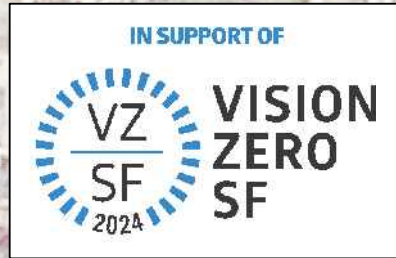

EXISTING STEADY DEMAND SEQUENCE

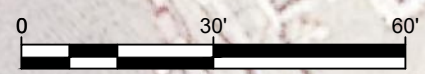
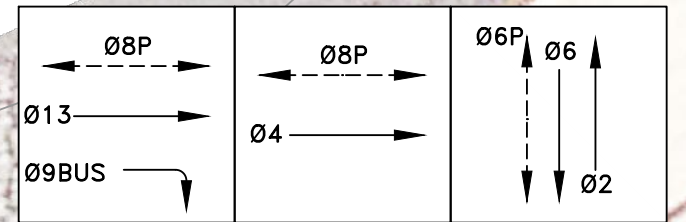

FUTURE IMPROVEMENTS (BY OTHERS)

- ① FRONTING OWNER TO CONSTRUCT BULBOUT

RECOMMENDED IMPROVEMENTS (NEAR-TERM PROJECT)

GENERAL: INSTALL LEADING PEDESTRIAN INTERVAL FOR ALL CROSSINGS

GENERAL: STRIPE HIGH-VISIBILITY CROSSWALK

RECOMMENDED IMPROVEMENTS (CAPITAL PROJECT)

- ② REMOVE EXISTING SIGNAL POLE AT NORTHWEST CORNER AND INSTALL NEW MAST ARM POLE WITH OVERHEAD TRAFFIC SIGNAL
- ③ CONSTRUCT RETAINING WALL, EXTEND ADJACENT SIDEWALK, AND CONSTRUCT CURB RAMPS
- ④ STRIPE AND SIGNALIZE NEW PEDESTRIAN CROSSING. ASSIGN TO Ø2P. SEE PROPOSED STEADY DEMAND SEQUENCE BELOW
- ⑤ STRIPE AND SIGNALIZE NEW PEDESTRIAN CROSSING. ASSIGN TO Ø4P. SEE PROPOSED STEADY DEMAND SEQUENCE BELOW
- ⑥ INSTALL SIGNALS ON NEW MAST ARM POLE
- ⑦ CONVERT #2 LANE TO "RIGHT TURN ONLY" LANE
- ⑧ INSTALL RIGHT TURN SIGNAL. ASSIGN SIGNAL TO Ø10 TO SEPARATE RIGHT TURNING VEHICLES AND NEW PEDESTRIAN CROSSING ACROSS ON-RAMP. INSTALL "NO TURN ON RED SIGN"

GENERAL: INSTALL APS FOR ALL CROSSINGS

GENERAL NOTES

NORTH SIDE OF ESSEX IS ONE POSSIBLE LOCATION FOR BAY BRIDGE BIKE PATH TOUCHDOWN

PROPOSED STEADY DEMAND SEQUENCE

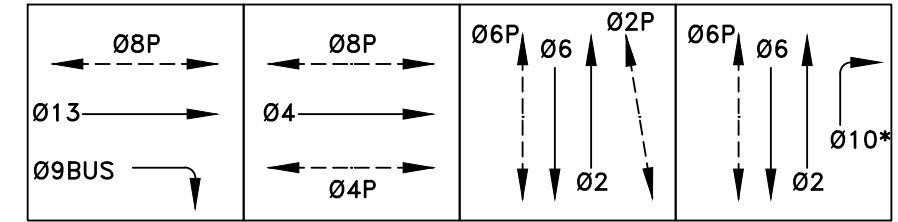

*NO RIGHT TURN ON RED

HARRISON STREET/ESSEX STREET/I-80 EB ON-RAMP

VISION ZERO PHASE 2 RAMP INTERSECTION IMPROVEMENTS

FEBRUARY 2019



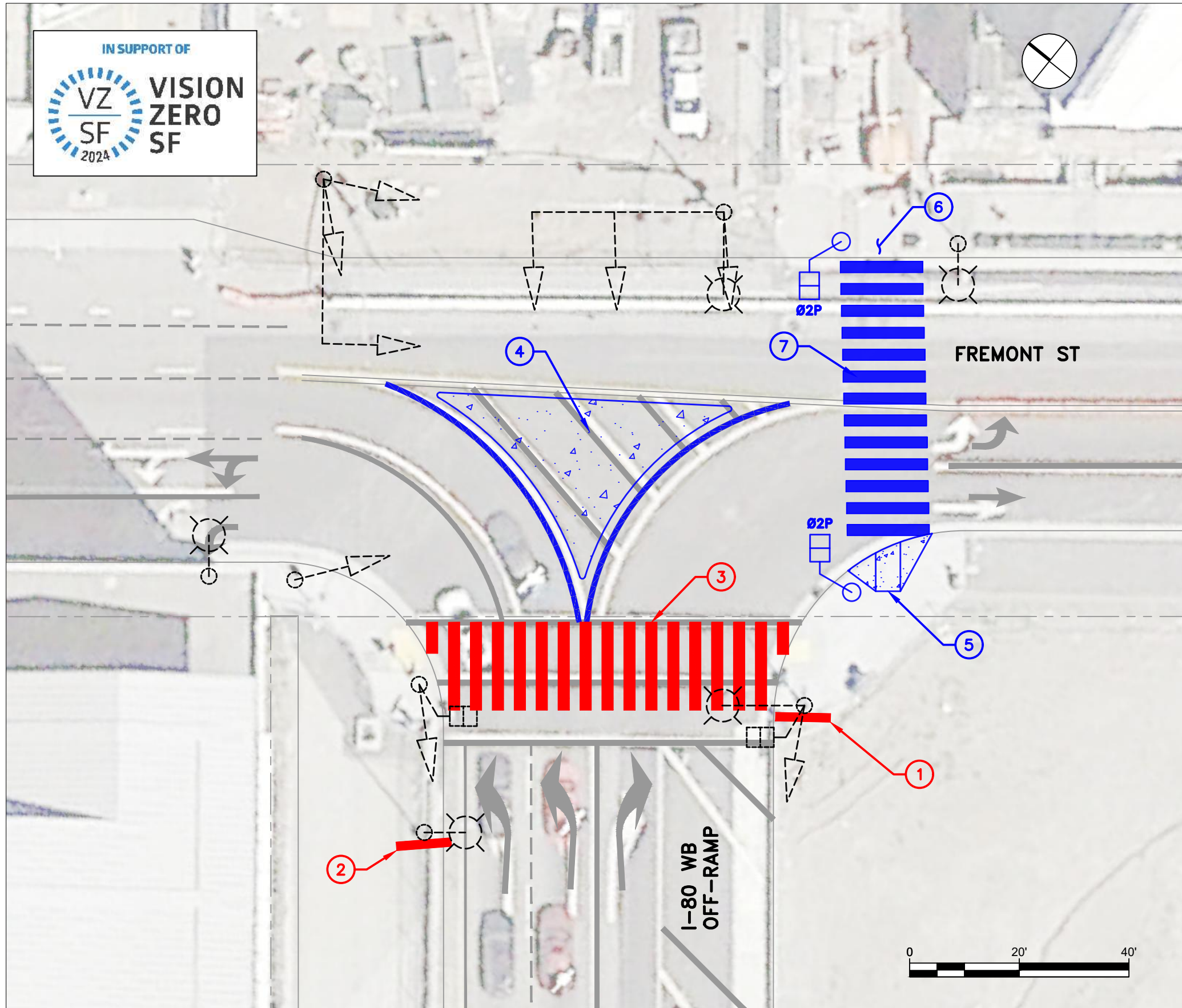

RECOMMENDED IMPROVEMENTS (NEAR-TERM)

- ① INSTALL NEAR-SIDE "NO RIGHT TURN ON RED" SIGN
- ② INSTALL NEAR-SIDE "NO LEFT TURN ON RED" SIGN
- ③ STRIPE HIGH VISIBILITY CROSSWALK

RECOMMENDED IMPROVEMENTS (CAPITAL PROJECT)

- ④ CONSTRUCT RAISED SPLITTER ISLAND
- ⑤ CONSTRUCT CURB RAMP
- ⑥ MODIFY PLAZA RAMP FOR PEDESTRIAN USE
- ⑦ STRIPE AND SIGNALIZE NEW PEDESTRIAN CROSSING AND ASSIGN TO Ø2P. SEE PROPOSED STEADY DEMAND SEQUENCE BELOW

EXISTING STEADY DEMAND SEQUENCE

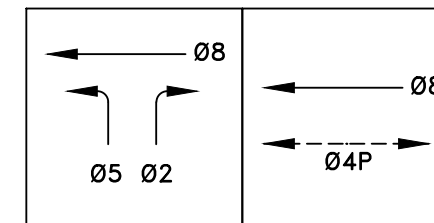

PROPOSED STEADY DEMAND SEQUENCE

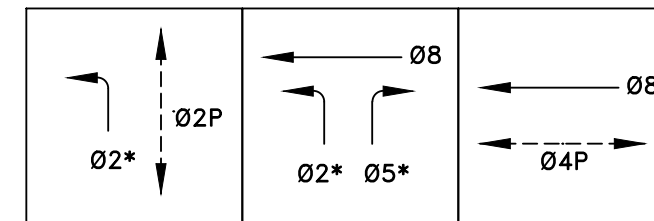

*"LEFT TURN ONLY" AND "RIGHT TURN ONLY" PHASES ARE RE-ASSIGNED FROM EXISTING

FREMONT STREET/I-80 WB OFF-RAMP
 VISION ZERO PHASE 2 RAMP INTERSECTION IMPROVEMENTS
 FEBRUARY 2019

APPENDIX D

Traffic Analysis Reports



San Francisco
County Transportation
Authority

Intersection: 13th St and Mission St: Existing

Cycle Time	90s	
Splits and Phases	<p>AM:</p> <p>Splits and Phases: 1: Mission St & 13th St & US 101 NB Off-Ramp</p> <p>PM:</p> <p>Splits and Phases: 1: Mission St & 13th St & US 101 NB Off-Ramp</p>	
	V/C Ratio (>0.85)	AM
	PM	N/A
LOS E/F Movements	AM	N/A
	PM	N/A
95th Percentile Queues (ft)	AM	EBT – 517, EBR – 396; WBT – 459; NBT – 238; SBL – 401, SBT – 157, SWR – 2972
	PM	EBT – 514, EBR – 400; WBT – 654; NBT – 129; SBL – 636, SBT – 650, SWR – 2032
Queuing Upstream Block Time during the Peak Hour	AM	EB blocked at Valencia – 59%; WB blocked at Van Ness – 7%; NB blocked at 14 th – 0%; SB blocked at Otis/McCoppin/Gough – SBL lanes 0-1%, SBT lanes 0%; SWR (101 Off-Ramp) blocked at mainline 101 – 30-37%
	PM	EB blocked at Valencia – 27%; WB blocked at Van Ness – 27-36%; NB blocked at 14 th – 0%; SB blocked at Otis/McCoppin/Gough – SBL lanes 21-52%, SBT lanes 22%; SWR (101 Off-Ramp) blocked at mainline 101 – 12%

Intersection: 13th St and Mission St: No 2-Way Otis, With Bus Lane
(Split phase between WB and WB Ramp)

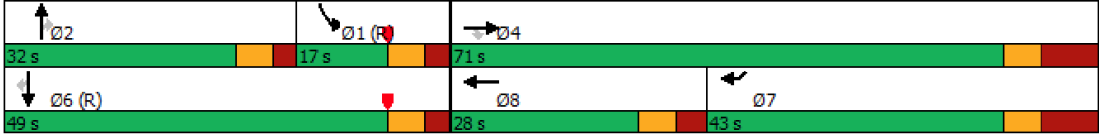
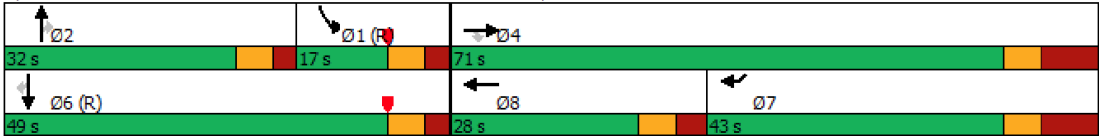
Cycle Time	120s	
Splits and Phases	<p>AM: Splits and Phases: 1: Mission St & 13th St & US 101 NB Off-Ramp</p>  <p>PM: Splits and Phases: 1: Mission St & 13th St & US 101 NB Off-Ramp</p> 	
New Crosswalk	N/A	
New Traffic Phases	Ph7 SWRT	
V/C Ratio (>0.85)	AM	WBT (0.89), NBT (0.88), SBL (1.75)
	PM	WBT (1.18), SBL (1.85)
LOS E/F Movements	AM	NBT(E), WBT(E), SBL(F)
	PM	WBT (F), SBL(F)
95th Percentile Queues (ft)	AM	EBT – 577, EBR – 93; WBT – 674; NBT – 675; SBL – 540, SBT – 500, SWR – 2437
	PM	EBT – 231, EBR – 88; WBT – 621; NBT – 563; SBL – 633, SBT – 631, SWR – 793
Queuing Upstream Block Time during the Peak Hour	AM	EB blocked at Valencia – 4%; WB blocked at Van Ness – 44-74%; NB blocked at 14 th – 73%; SB blocked at Otis/McCoppin/Gough – SBL lanes 54-95%; SWR (101 Off-Ramp) blocked at mainline 101 – 2%
	PM	EB blocked at Valencia – 0%; WB blocked at Van Ness – 56-92%; NB blocked at 14 th – 1%; SB blocked at Otis/McCoppin/Gough – SBL lanes 95-96%; SWR (101 Off-Ramp) blocked at mainline 101 – 0%
NBT Bus Only Lane Block Time during the Peak Hour	AM	Blocked – 69%
	PM	Blocked – 16%

NBT Bus Only lane assumed from Erie Street to 13th Street – results in a single-lane section on Mission Street from Erie Street to ~135 feet south of 13th Street

Intersection: 13th St and Mission St: No 2-Way Otis, No Bus Lane (Concurrent WB Ramp and WB 13th)

Cycle Time	110s	
Splits and Phases	<p>AM:</p> <p>PM:</p>	
New Crosswalk	N/A	
New Traffic Phases	N/A	
V/C Ratio (>0.85)	AM	SBL (0.91)
	PM	SBL (0.98), WBT (0.94)
LOS E/F Movements	AM	SBL(E)
	PM	SBL(E)
95th Percentile Queues (ft)	AM	EBT – 372; WBT – 245; NBT – 213; SBL – 639, SBT – 394, SWR – 186
	PM	EBT – 251; WBT – 741; NBT – 193; SBL – 567, SBT – 295, SWR – 103
Queuing Upstream Block Time during the Peak Hour	AM	EB blocked at Valencia – 12-48%; WB blocked at Van Ness – 0%; NB blocked at 14 th 0%; SB blocked at Otis/McCoppin/Gough – SBL lanes 38-67%; SWR (101 Off-Ramp) blocked at mainline 101 – 0%
	PM	EB blocked at Valencia – 0%; WB blocked at Van Ness – 28-39%; NB blocked at 14 th – 0%; SB blocked at Otis/McCoppin/Gough – SBL lanes 1-4%; SWR (101 Off-Ramp) blocked at mainline 101 – 0%

Intersection: 13th St and Mission St: With 2-Way Otis, With Bus Lane

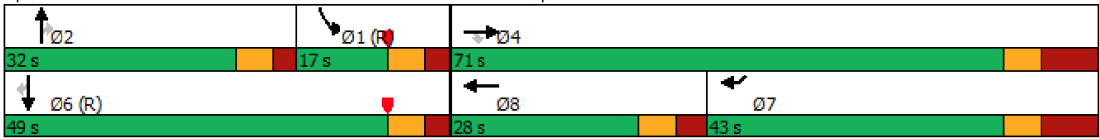
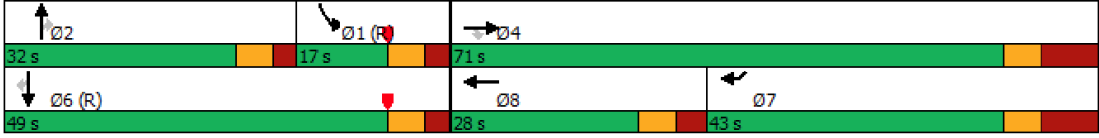
Cycle Time	120s	
Splits and Phases	AM: Splits and Phases: 1: Mission St & 13th St & US 101 NB Off-Ramp 	
	PM: Splits and Phases: 1: Mission St & 13th St & US 101 NB Off-Ramp 	
New Crosswalk	N/A	
New Traffic Phases	Ph7 SWRT	
V/C Ratio (>0.85)	AM	WBT (0.89), SBL (1.75), SWR (1.05)
	PM	WBT (1.18), SBL (1.85), SWR (0.99)
LOS E/F Movements	AM	SBL (F), SWR (F)
	PM	WBT (F), SBL (F), SWR (E)
95th Percentile Queues (ft)	AM	EBT –539 ; EBR – 78, WBT – 655; NBT – 763, SBL – 159, SBT –163, SWR – 167
	PM	EBT – 135; EBR – 82, WBT – 628; NBT – 499, SBL – 105, SBT –117, SWR – 178
Queuing Upstream Block Time during the Peak Hour	AM	EB blocked at Valencia – 2%; WB blocked at Van Ness – 18-35%; NB blocked at 14 th – 17%; SB blocked at Otis/McCoppin/Gough – SBL lanes 72-94%; SWR (101 Off-Ramp) blocked at mainline 101 – 73%
	PM	EB blocked at Valencia – 0%; WB blocked at Van Ness – 54-98%; NB blocked at 14 th – 0%; SB blocked at Otis/McCoppin/Gough – SBL lanes 84-89%; SWR (101 Off-Ramp) blocked at mainline 101 – 73%
NBT Bus Only Lane Block Time during the Peak Hour	AM	Blocked – 41%
	PM	Blocked –14%

NBT Bus Only lane assumed from Erie Street to 13th Street – results in a single-lane section on Mission Street from Erie Street to ~135 feet south of 13th Street

Intersection: 13th St and Mission St: With 2-Way Otis, No Bus Lane

Cycle Time	120s	
Splits and Phases	<p>AM: Splits and Phases: 1: Mission St & 13th St & US 101 NB Off-Ramp</p> <p>PM: Splits and Phases: 1: Mission St & 13th St & US 101 NB Off-Ramp</p>	
New Crosswalk	N/A	
New Traffic Phases	Ph7 SWRT	
V/C Ratio (>0.85)	AM	WBT (0.89), SBL (1.75), SWR (1.05)
	PM	WBT (1.18), SBL (1.85), SWR (0.99)
LOS E/F Movements	AM	SBL (F), SWR (F)
	PM	WBT (F), SBL (F), SWR (E)
95th Percentile Queues (ft)	AM	EBT – 581, EBR – 73; WBT – 668; NBT – 17; SBL – 166, SBT – 122, SWR – 85
	PM	EBT – 228, EBR – 100; WBT – 604; NBT – 166; SBL – 102, SBT – 105, SWR – 97
Queuing Upstream Block Time during the Peak Hour	AM	EB blocked at Valencia – 5%; WB blocked at Van Ness – 20-27%; NB blocked at 14 th – 0%; SB blocked at Otis/McCoppin/Gough – SBL lanes 81-96%, SBT lanes 6-7%, SBR lanes 0%; SWR (101 Off-Ramp) blocked at mainline 101 – 73%
	PM	EB blocked at Valencia – 10% ; WB blocked at Van Ness – 11-16%; NB blocked at 14 th – 0%; SB blocked at Otis/McCoppin/Gough – SBL lanes 63-95%, SBT lanes 13%, SBR lanes 0%; SWR (101 Off-Ramp) blocked at mainline 101 – 73%

Critical ped Xing Ø8 WBT, ped Xing distance =70'. Assume W5s, FDW+Y+R=23s. Walk speed 3ft/s.

Intersection: 13th St and Mission St: With 2-Way Otis, Bus Lane, Half Crossing East Xwalk

Cycle Time	120s	
Splits and Phases	AM: Splits and Phases: 1: Mission St & 13th St & US 101 NB Off-Ramp 	
	PM: Splits and Phases: 1: Mission St & 13th St & US 101 NB Off-Ramp 	
New Crosswalk	N/A	
New Traffic Phases	Ph7 SWRT	
V/C Ratio (>0.85)	AM	WBT (0.86), NBT (0.93), SBL (0.99), SWR (0.97)
	PM	WBT (1.03), SBL (1.04), SWR (0.99)
LOS E/F Movements	AM	NBT (F), NBR (F), SBL (F), SBR (E)
	PM	WBT (E), NBT (E), SBL (F), SWR (E)
95th Percentile Queues (ft)	AM	EBT – 474; EBR – 73, WBT – 657; NBT – 459; SBL – 163, SBT –170, SWR – 110
	PM	EBT – 205; EBR – 93, WBT – 621; NBT – 659; SBL – 69, SBT – 61, SWR – 116
Queuing Upstream Block Time during the Peak Hour	AM	EB blocked at Valencia – 2% WB blocked at Van Ness – 17-30%; NB blocked at 14 th – 89%; SB blocked at Otis/McCoppin/Gough – SBL lanes 58-86%; SWR (101 Off-Ramp) blocked at mainline 71%
	PM	EB blocked at Valencia – 0%; WB blocked at Van Ness – 37-53%; NB blocked at 14 th – 9%; SB blocked at Otis/McCoppin/Gough – SBL lanes 80-81%; SWR (101 Off-Ramp) blocked at mainline 73%
NBT Bus Only Lane Block Time during the Peak Hour	AM	Blocked – 82%
	PM	Blocked –37%

NBT Bus Only lane assumed from Erie Street to 13th Street – results in a single-lane section on Mission Street from Erie Street to ~135 feet south of 13th Street

Critical ped Xing Ø2 NBT, ped Xing distance =33'. Assume W5s, FDW+Y+R=11s. Walk speed 3ft/s. Min ph time is 16s.

Intersection: 13th St and Mission St: With 2-Way Otis, No Bus Lane, Half Crossing East Xwalk

Cycle Time	120s	
Splits and Phases	AM: Splits and Phases: 1: Mission St & 13th St & US 101 NB Off-Ramp 	
	PM: Splits and Phases: 1: Mission St & 13th St & US 101 NB Off-Ramp 	
New Crosswalk	N/A	
New Traffic Phases	Ph7 SWRT	
V/C Ratio (>0.85)	AM	WBT (0.86), SBL (0.99), SWR (0.97)
	PM	WBT (1.03), SBL (1.04), SWR (0.99)
LOS E/F Movements	AM	NBT (E), NBR (F), SBL (F), SBR (E)
	PM	WBT (E), SBL (F), SBR (E)
95th Percentile Queues (ft)	AM	EBT – 494, EBR – 49; WBT – 606; NBT – 649; SBL – 164, SBT – 160, SWR – 87
	PM	EBT – 194, EBR – 59; WBT – 599; NBT – 202; SBL – 103, SBT – 103, SWR – 85
Queuing Upstream Block Time during the Peak Hour	AM	EB blocked at Valencia – 3%; WB blocked at Van Ness – 20-38%; NB blocked at 14 th – 37-83%; SB blocked at Otis/McCoppin/Gough – SBL lanes 61-87%, SBT lanes 17-27%, SBR lanes 0%; SWR (101 Off-Ramp) blocked at mainline 101 – 73%
	PM	EB blocked at Valencia – 0%; WB blocked at Van Ness – 36-87%; NB blocked at 14 th – 0%; SB blocked at Otis/McCoppin/Gough – SBL lanes 80-82%, SBT lanes 36-66%, SBR lanes 7%; SWR (101 Off-Ramp) blocked at mainline 101 – 73%

Intersection: 13th St and Mission St: No 2-Way Otis, No Bus Lane

Cycle Time	120s	
Splits and Phases	<p>AM: Splits and Phases: 1: Mission St & 13th St & US 101 NB Off-Ramp</p> <p>PM: Splits and Phases: 1: Mission St & 13th St & US 101 NB Off-Ramp</p>	
New Crosswalk	N/A	
New Traffic Phases	Ph7 SWRT	
V/C Ratio (>0.85)	AM	WBT (0.89), SBL (1.75),
	PM	WBT (1.18), SBL (1.85)
LOS E/F Movements	AM	WBT (E), SBL (F)
	PM	WBT (F), SBL (F)
95th Percentile Queues (ft)	AM	EBT – 546, EBR – 13; WBT – 723; NBT – 534; SBL – 616, SBT – 604, SWR – 1108
	PM	EBT – 223, EBR – 52; WBT – 605; NBT – 380; SBL – 537, SBT – 588, SWR – 468
Queuing Upstream Block Time during the Peak Hour	AM	EB blocked at Valencia – 1-11%; WB blocked at Van Ness – 40-69%; NB blocked at 14 th – 0%; SB blocked at Otis/McCoppin/Gough – SBL lanes 84-91%, SBT lanes 0-23%, SBR lanes 0%; SWR (101 Off-Ramp) blocked at mainline 101 – 0%
	PM	EB blocked at Valencia – 0%; WB blocked at Van Ness – 53-93%; NB blocked at 14 th – 0%; SB blocked at Otis/McCoppin/Gough – SBL lanes 76-86%, SBT lanes 42%, SBR lanes 3%; SWR (101 Off-Ramp) blocked at mainline 101 – 0%

Intersection: South Van Ness and 13th St: Existing

Cycle Time	90s	
Splits and Phases	AM: Splits and Phases: 2: South Van Ness Ave & 13th St 	
	PM: Splits and Phases: 2: South Van Ness Ave & 13th St 	
V/C Ratio (>0.85)	AM	EBR (1.27)
	PM	N/A
LOS E/F Movements	AM	EBR (F)
	PM	N/A
95th Percentile Queues (ft)	AM	EBT –301, EBR – 529; WBT – 248; NBT – 203; SBL –407, SBT – 443
	PM	EBT – 433, EBR – 421; WBT – 609; NBT – 187; SBL – 599, SBT – 599
Queuing Upstream Block Time during the Peak Hour	AM	EB blocked at Otis/Mission –2%; WB blocked at Folsom St – 0%; NB blocked at 14 th – 3%-9%; SB blocked at 12 th – 3-4%
	PM	EB blocked at Otis/Mission – 1-12%; WB blocked at Folsom St – 6-10%; NB blocked at 14 th – 2%; SB blocked at 12 th – 19-24%

Intersection: South Van Ness and 13th St: South Van Ness with No Left Turn

Cycle Time	120s	
Splits and Phases	AM: Splits and Phases: 2: South Van Ness Ave & 13th St 	
	PM: Splits and Phases: 2: South Van Ness Ave & 13th St 	
New Crosswalk	N/A	
New Traffic Phases	Dedicated WB Bike/Ped Crossing Phase (Ø9), protected WB RT (Ø10)	
V/C Ratio (>0.85)	AM	EBR (1.08)
	PM	EBT (0.91), SBT (0.90)
LOS E/F Movements	AM	EBR (E)
	PM	N/A
95th Percentile Queues (ft)	AM	EBT – 373; EBR – 321; WBT – 783; NBT – 182; SBT – 640
	PM	EBT – 370; EBR – 279; WBT – 653; NBT – 207; SBT – 668
Queuing Upstream Block Time during the Peak Hour	AM	EB blocked at Otis/Mission – 0%; WB blocked at Folsom St – 10-26%; NB blocked at 14 th – 10-26%; SB blocked at 12 th – 31-35%
	PM	EB blocked at Otis/Mission – 0%; WB blocked at Folsom St – 18-55%; NB blocked at 14 th – 3-11%; SB blocked at 12 th – 53-69%

Intersection: South Van Ness and 13th St: South Van Ness With Left Turn

Cycle Time	120s	
Splits and Phases	AM: Splits and Phases: 2: South Van Ness Ave & 13th St 	
	PM: Splits and Phases: 2: South Van Ness Ave & 13th St 	
New Crosswalk	N/A	
New Traffic Phases	Ph1 SBL, Ph10 WBL	
V/C Ratio (>0.85)	AM	EBT (0.94), EBR (1.24), NBT (0.91)
	PM	EBT (0.99), SBT (0.93)
LOS E/F Movements	AM	EBT (E), EBR (F), WBL (E), NBT (F), SBL (E)
	PM	WBL (E), WBR (E), SBL (E)
95th Percentile Queues (ft)	AM	EBT – 437, EBR – 456; WBT – 586; NBT – 186; SBL – 772, SBT – 561
	PM	EBT – 600, EBR – 428; WBT – 653; NBT – 197; SBL – 746, SBT – 571
Queuing Upstream Block Time during the Peak Hour	AM	EB blocked at Otis/Mission –1%; WB blocked at Folsom St – 2%; NB blocked at 14 th – 55-58%; SB blocked at 12 th – SBL lanes 22%, SBT lanes 88-95%
	PM	EB blocked at Otis/Mission – 9%; WB blocked at Folsom St – 15-44%; NB blocked at 14 th – 4-19%; SB blocked at 12 th – SBL lanes 21%, SBT lanes 69-89%

Intersection: 7TH Midblock: Existing

Cycle Time	Yield controlled	
95th Queue (ft)	AM	141-150 ft
	PM	65-67 ft
Queuing Penalty (veh)	AM	1 veh at the off-ramp (midblock and Bryant split)
	PM	0 veh at the off-ramp (midblock and Bryant split)
95th Percentile Queues (ft)	AM	NBT – 45, NEL – 90
	PM	NBT – 11, NEL – 67
Queuing Upstream Block Time during the Peak Hour	AM	Blocked at the off-ramp (midblock and Bryant split) – 0%
	PM	Blocked at the off-ramp (midblock and Bryant split) – 0%

I-80 Off Ramp queuing capacity

- 250' from midblock intersection to Off-Ramp Split (midblock and Bryant)
- 600' from 7th (either approach) to I-80 off-ramp junction at mainline

Intersection: 7TH Midblock: With Project 1 Yield Lane

Cycle Time	Yield controlled	
95th Queue	AM	262 ft
	PM	136 ft
Queuing Penalty	AM	22 veh at the off-ramp (midblock and Bryant split)
	PM	0 veh at the off-ramp (midblock and Bryant split)
95th Percentile Queues (ft)	AM	NBT – 36, NEL – 262
	PM	NBT – 185, NEL – 136
Queuing Upstream Block Time during the Peak Hour	AM	Blocked at the off-ramp (midblock and Bryant) split) – 3%
	PM	Blocked at the off-ramp (midblock and Bryant split) – 0%

I-80 Off Ramp queuing capacity

- 250' from midblock intersection to Off-Ramp Split (midblock and Bryant)
- 600' from 7th (either approach) to I-80 off-ramp junction at mainline

Intersection: 7TH Midblock: With Project 2 Yield Lanes

Cycle Time	Yield controlled	
95th Queue	AM	117-213ft
	PM	127-168ft
Queuing Penalty	AM	2 veh
	PM	8 veh
95th Percentile Queues (ft)	AM	NBT – 31, NEL – 213
	PM	NBT – 205, NEL – 168
Queuing Upstream Block Time during the Peak Hour	AM	Blocked at the off-ramp (midblock and Bryant split) – 1%
	PM	Blocked at the off-ramp (midblock and Bryant split) – 7%

I-80 Off Ramp queuing capacity

- 250' from midblock intersection to off-ramp split (midblock and Bryant)
- 600' from 7th (either approach) to I-80 off-ramp junction at mainline

Intersection: 7TH St and Bryant St: Existing

Cycle Time	90s	
Splits and Phases	AM: Splits and Phases: 1: Bryant St & 7th St & I-80 EB Off-Ramp 	
	PM: Splits and Phases: 1: Bryant St & 7th St & I-80 EB Off-Ramp 	
V/C Ratio (>0.85)	AM	N/A
	PM	N/A
LOS E/F Movements	AM	N/A
	PM	N/A
95th Percentile Queues (ft)	AM	EBL – 252; NWT – 293, NET – 341, NBT – 45
	PM	EBL – 107; NWT – 415, NET – 490, NBT – 11
Queuing Upstream Block Time during the Peak Hour	AM	I-80 EB Off Ramp (midblock and Bryant split) – 9%
	PM	NEB blocked at 8th St – 6%

I-80 Off Ramp queuing capacity

- 250' from midblock intersection to off-ramp split (midblock and Bryant)
- 600' from 7th (either approach) to I-80 off-ramp junction at mainline

Intersection: 7TH St and Bryant St: with Project

Cycle Time	90s	
Splits and Phases	AM: 	
	PM: 	
New Crosswalk	N/A	
New Traffic Phases	Ph11P, Ph3 NWL	
V/C Ratio (>0.85)	AM	EBL (0.94), NWR (0.86)
	PM	NWT (0.95), NET (0.93)
LOS E/F Movements	AM	NWR (E), EBL (E)
	PM	N/A
95th Percentile Queues (ft)	AM	EBL – 309; NWT – 272, NET – 385
	PM	EBL – 169; NWT – 555, NET – 536
Queuing Upstream Block Time during the Peak Hour	AM	I-80 EB Off Ramp (midblock and Bryant split) – 0-6%
	PM	I-80 EB Off Ramp (midblock and Bryant split) – 0% NWT blocked at Brannan – 2% NET blocked at 8 th – 2 - 11%

I-80 Off Ramp queuing capacity

- 250' from midblock intersection to off-ramp split (midblock and Bryant)
- 600' from 7th (either approach) to I-80 off-ramp junction at mainline

Intersection: 6TH and Brannan: Existing

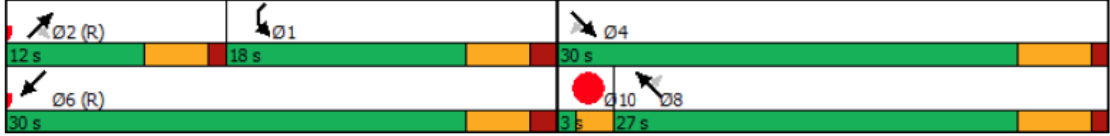
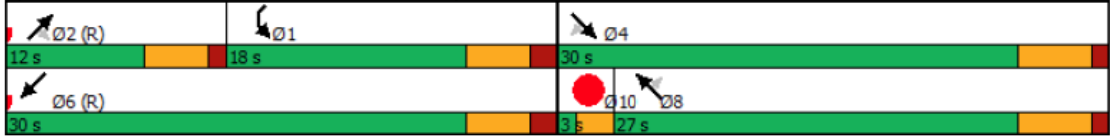
Cycle Time	60s	
Splits and Phases	AM: Splits and Phases: 1: Brannan St & I-280 On/Off-Ramp/6th St 	
	PM: Splits and Phases: 1: Brannan St & I-280 On/Off-Ramp/6th St 	
V/C Ratio (>0.85)	AM	SET (0.89), NWT (1.14), NWR (0.90)
	PM	SET (1.13), NWT (1.09), NET (1.46), SWL (0.88)
LOS E/F Movements	AM	NWT (F)
	PM	NET (F), NWT (F), SET(F)
95th Percentile Queues (ft)	AM	SET – 312, SER – 59; NWT – 498, NET–159; SWL –174, SWT –100
	PM	SET – 591, SER –700; NWT – 876, NWR-672, NET–7180; SWL –409, SWT –123, SWL-378
Queuing Upstream Block Time during the Peak Hour	AM	SEB blocked at Bryant – 0%; NWB blocked at Freeway Main Line – 0%; NEB blocked at 7 th St – 0%; SWB blocked at 5 th – SBL lanes 0%, SBT lanes 0%
	PM	SEB blocked at Bryant – SET 74-90%, SER 74%; NWB blocked at Freeway Main Line– 22-27%; NEB blocked at 7 th St – NET 61%, NETR 79%; SWB blocked at 5 th – 0%

Queue storage from Brannan to I-280 mainline = 3000'

Intersection: 6TH and Brannan: with Project (Open Xwalk Across Ramp and Ramp NBRT signal)

Cycle Time	120s	
Splits and Phases	AM: Splits and Phases: 1: Brannan St & I-280 On/Off-Ramp/6th St 	
	PM: Splits and Phases: 1: Brannan St & I-280 On/Off-Ramp/6th St 	
New Crosswalk	South Crosswalk on I-280 On/Off Ramp (Ph2)	
New Traffic Phases	Ph12P (NWB East Xwalk Xing Brannan) and protected Ph9 NWR	
V/C Ratio (>0.85)	AM	NWR (1.27), SWL (0.87)
	PM	SET (1.10), NWT (0.94), NWR (0.91), NER (1.10), SWL (1.09)
LOS E/F Movements	AM	NWR (F), SWL (E)
	PM	SET(F), NER(F), SWL(F)
95th Percentile Queues (ft)	AM	SET – 363, SER – 66; NWT – 2920, NET–200, NER-138; SWL –246, SWT –179
	PM	SET – 510, SER – 179; NWT – 1032, NET–698; SWL –271, SWT –697
Queuing Upstream Block Time during the Peak Hour	AM	SEB blocked at Bryant – 0%; NWB blocked at Freeway Main Line – 25-56%; NEB blocked at 7 th St – 0%; SWB blocked at 5 th – 0%
	PM	SEB blocked at Bryant – SET lanes 8-15% NWB blocked at Freeway Main Line– 0%; NEB blocked at 7 th St– 65%; SWB blocked at 5 th –SWT lanes 29%

Queue storage from Brannan to I-280 mainline = 3000'

Intersection: 6TH and Brannan: with Project (Ramp NBRT signal only)

Cycle Time	120s AM, 90s PM	
Splits and Phases	AM: 	
	PM: 	
New Crosswalk	None	
New Traffic Phases	Ph12P (NWB East Xwalk Xing Brannan) and protected Ph9 NWR	
V/C Ratio (>0.85)	AM	NBR (1.04), SWL (0.87), NET (0.93), NER (0.87)
	PM	SET (1.11), NWT (0.94), NWR (0.94), NET(0.86), SWL (0.90)
LOS E/F Movements	AM	NWR (E), NET(F), NER(E), SWL (E)
	PM	NET(E), SET (F)
95th Percentile Queues (ft)	AM	SET – 232, SER – 32; NWT – 1240, NET–258, NER-153; SWL –205, SWT –221
	PM	SET – 521, SER – 210; NWT – 607, NET–376; SWL –280, SWT –527
Queuing Upstream Block Time during the Peak Hour	AM	SEB blocked at Bryant – 0%; NWB blocked at Freeway Main Line – 0%; NEB blocked at 7 th St – 0%; SWB blocked at 5 th – 0%
	PM	SEB blocked at Bryant – SET lanes 8% NWB blocked at Freeway Main Line– 0%; NEB blocked at 7 th St– 0%; SWB blocked at 5 th –SWT lanes 2%

Queue storage from Brannan to I-280 mainline = 3000'

APPENDIX E

Outreach Report Round 1



San Francisco
County Transportation
Authority

MEMO

To: SFCTA SoMa Ramps Project Team
From: Civic Edge Consulting
Date: May 17, 2018
Subject: Round One SoMa Ramp Intersections Project Outreach Summary Report

As the San Francisco County Transportation Authority (SFCTA) undertakes its second phase of the South of Market neighborhood ramp intersections safety study, community and stakeholder participation has been a priority of the project team. The following Outreach Summary Report outlines the engagement strategies for Round One of the Study, taking place between February and May 2018.

The goal for Outreach Round 1 of the SoMa Ramp Intersections Safety Study (Vision Zero Ramp Study 2) was to solicit input from community stakeholders to help develop recommended safety improvements to 10 pre-selected ramp intersections in the neighborhood.

Feedback collected during Outreach Round 1 of this study will help to identify issues and needs of the community stakeholders and to develop the improvement recommendations.

The first round of outreach included the following tools:

- A broadly fielded survey translated into Spanish, Chinese, and Filipino;
- A mailer to promote the survey, translated into Spanish, Chinese, and Filipino;
- Online promotions including an educational video, eNewsletter, and English social media posts promoting the study and survey;
- Additional in-language social media ads targeting Spanish, Chinese, and Filipino speakers;
- Outreach to community-based organizations (CBOs), partner agencies, and other targeted groups with an interest in the project;
- In-person presentations to CBOs, partner agencies, and other organizations by SFCTA staff; and
- Intercept outreach in the study area, in collaboration with Vision Zero SF.

SoMa Ramp Intersections Survey

A survey was developed by the project team to learn more about people's experiences at the 10 intersections within the study area and gather feedback on potential safety improvements. The survey took approximately six minutes to complete and was translated into Spanish, Chinese, and Filipino. All participants were invited to sign up to receive email updates on this study.

Prior to answering questions, survey participants were provided the following background information about the study:

There are many intersections in San Francisco's South of Market neighborhood where freeway on- or off-ramps intersect city streets. Many of these ramps are close to schools, single room occupancy hotels, and senior centers, which attract populations at high risk of injury from traffic collisions.

The Transportation Authority and the SFMTA are exploring ways to improve safety for all travelers as we work toward San Francisco's Vision Zero goal to eliminate traffic deaths by 2024. This study will focus on a selected of freeway ramp intersections in SoMa (the remaining intersections are being addressed through other planning efforts).

As part of this study, we are seeking to learn more about people who travel in SoMa and better understand your travel experiences around freeway on- and off-ramp intersections.

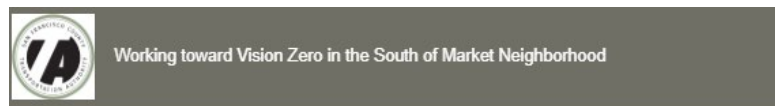

Freeway Ramp Intersection #1: Mission, Otis, Duboce, & 13th streets (U.S. 101 NB off-ramp)
[Google Street View](#)

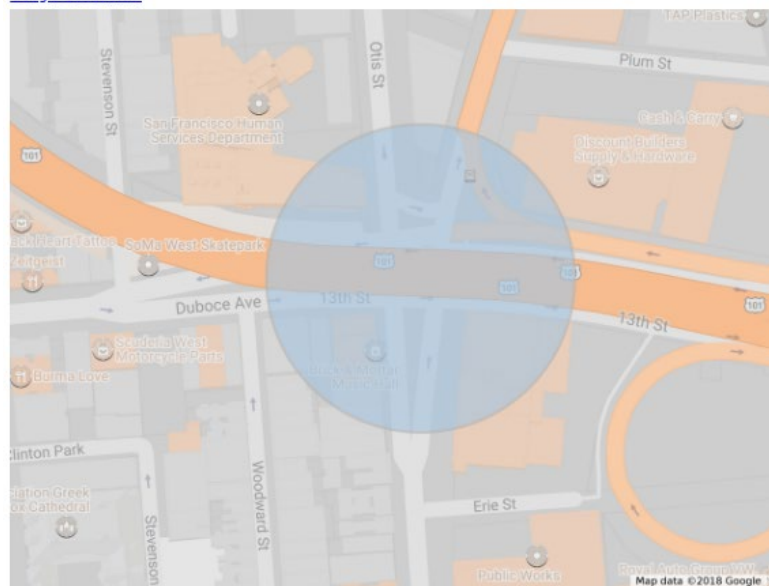

Please select any safety concerns you have when using this intersection:

- Unsafe traffic speeds
- Poor street lighting at night
- Poor traffic signal visibility
- Streets are difficult to cross for people walking
- Streets are difficult to cross for people biking
- No issues

Do you have other safety concerns or suggestions about how to improve this intersection?

Detail from online survey

Participants had the option to answer specific questions related to the 10 intersections being studied and answer general questions about traveling in SoMa or only answer general questions about traveling in SoMa.

Specific intersection questions included identifying any safety concerns about each intersection, including:

- Unsafe traffic speeds
- Poor street lighting at night
- Poor traffic signal visibility
- Streets are difficult to cross for people walking
- Streets are difficult to cross for people biking
- No issues

They could also offer open-ended feedback to the question: Do you have other safety concerns or suggestions about how to improve this intersection?

All respondents were asked to “Please describe your overall experience traveling in the SoMa neighborhood. Please share any overarching concerns or let us know how your travel experience in SoMa could be improved.”

Additionally, data was collected about when, where, and why participants travelled through SoMa and demographic information about home and work zip codes, age, income, gender, and ethnicity. We received the following responses from the survey:

- English – 807 responses
- Chinese – 14 responses
- Spanish – 5 responses
- Filipino – 1 responses

It is important to note that the language of the survey used does not indicate the ethnicity of the respondent pool, as many individuals tend to take surveys in English even if it is offered in a language they may be more familiar with. The self-identified ethnicities of the respondents are listed below.

Five common themes were apparent during this portion of the outreach and analysis, raised primarily in the general comments section:

- **Pedestrian Safety:** Focuses on the comments related to the experience of traveling through SoMa on-foot and/or with a mobility or assistive aid device. These comments do not directly acknowledge the root causes of such challenges, but rather the experience of traveling as a pedestrian itself.
- **Bicycle Safety and Infrastructure:** Refers to the general comments that focus on traveling through SoMa from the point of view of a cyclist while considering the bicycle infrastructure available to-date.
- **Motorist Behavior:** Refers to comments from motorists that are traveling through SoMa. The comments include confusion of motorists when they approach an intersection without warning of crosswalk or clear navigation direction.
- **Street and Site Design:** Focuses on the experience of traveling through SoMa either as a pedestrian, cyclist, motorist, or transit/TNC rider. Unlike the previous two categories, this theme applies to respondents whose reported challenges in navigating SoMa are the direct result of the configuration of the road, highway, sidewalk, or cycling networks. This cause and effect commentary is either directly acknowledged by the respondent or implied based on the information provided in the comments.
- **Encampments:** Refers to comments where the respondent’s primary challenge is in navigating around or through areas with homeless encampments.
- **Other:** A theme used in cases where none of the above apply, typically in situations where a general or unrelated opinion about SoMa is provided.

The survey revealed that **Street and Site Design** is the top theme related to navigating SoMa.

Within the general comments section, several respondents acknowledged that the configuration of the streets and freeway ramps play a role in the causes and effects of traveling as a pedestrian, cyclist, motorist, or transit/TNC rider. This includes challenges related to: wayfinding as a motorist, visibility as a pedestrian, navigating shared streets with curbside cycling infrastructure as both a pedestrian and cyclist, confusion or delays in merging from highways to local roads and vice versa for all modes, etc.

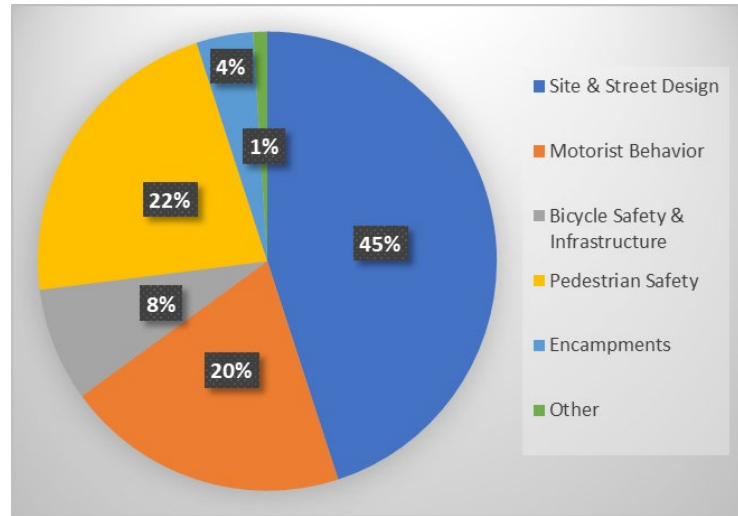

Figure 1: Themes of Survey Respondents Comments

The table below shows the summary of the survey respondents' experience using the study intersection ramps. Majority of the respondents identified "Difficult to Cross for People Walking" as their primary street safety concern for all the study intersections except for Essex and Harrison Street. The respondents also specified "Unsafe Traffic Speeds" as another area of street safety issue for most of the study intersections. For more information, see attached appendix A.

Intersection	Unsafe Traffic Speeds	Poor Street Lighting	Poor Traffic Signals	Difficult to Cross for People Walking	Difficult to Cross for People Biking	No Issues
1. Mission, Otis, Duboce, & 13th streets	40%	31%	22%	62%	43%	20%
2. South Van Ness Avenue & 13th Street	37%	26%	22%	61%	39%	27%
3. 8th Street between Bryant & Harrison streets	35%	14%	16%	49%	26%	38%
4. 8th Street & Bryant Street	34%	19%	21%	57%	33%	31%
5. 7th Street & Harrison Street	34%	19%	19%	52%	30%	37%
6. 7th Street between Bryant & Harrison streets	37%	21%	21%	47%	26%	37%
7. 7th Street & Bryant Street	36%	18%	18%	53%	29%	36%
8. 6th Street & Brannan Street	43%	20%	21%	60%	38%	29%
9. Fremont Street between Howard & Folsom streets	33%	13%	18%	46%	27%	44%
10. Essex Street and Harrison Street	30%	23%	17%	44%	26%	46%

Table 1: Summary of Survey Results

Mailer

A postcard was sent to approximately 15,000 addresses in SoMa within a few blocks of the ramp intersections. A map of the mailing area can be seen in the image to the right.

The postcard provided information about the project itself and instructions on how to subscribe to informational emails. Links to participate in the survey were included in English, Spanish, Chinese, and Filipino. The mailer was delivered the week of April 16, 2018.

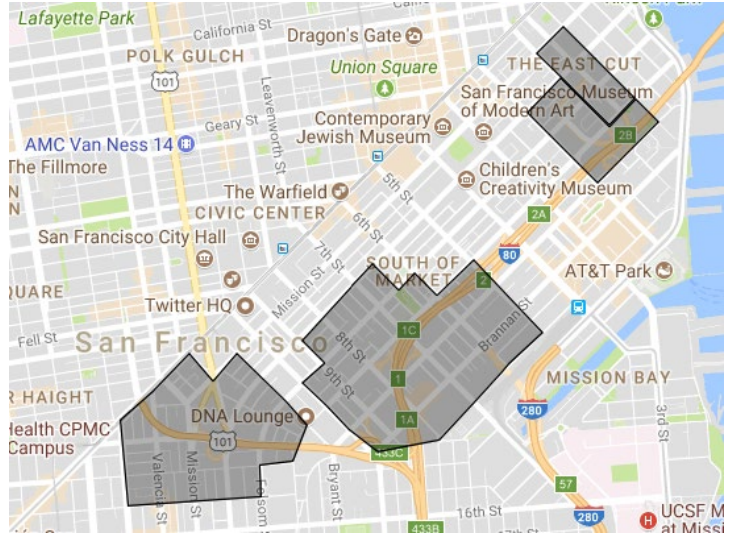

Map of SoMa Ramp Study Mail Distribution

Online Promotions

To spread the word about the SoMa Ramp Intersections Study and increase engagement, SFMTA mounted an online campaign that included an educational video, eNewsletter, and social media posts and ads.

In-Language Social Media Ads

Knowing that one in four SoMa residents self-identify as speaking English “less than very well,” connecting with a multilingual audience was a priority for the project team.

To encourage participation in the survey by residents more comfortable communicating in Spanish, Chinese and Filipino, targeted, in-language Facebook advertisements were created. The ads ran between April 13 and 27, 2018. A total budget of \$150 was used for ads in Spanish, Chinese and Filipino targeting residents who speak those languages with the following zip codes: 94107, 94105, and 94103.

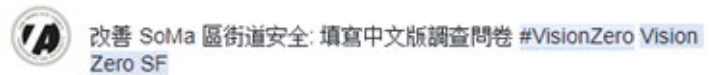

Surveys were also shared in the newsletter of District 6 Supervisor Jane Kim, the San Francisco Bicycle Coalition, Walk San Francisco, and the Yerba Buena CBD.

Sample Facebook ad

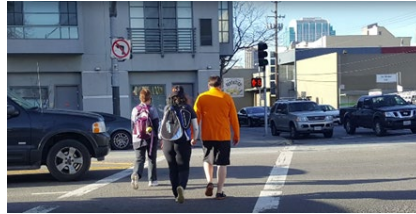
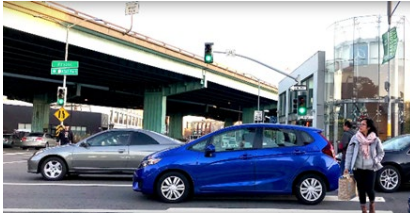

Images used in the in-language Facebook ads

The ads reached thousands of SoMa residents over their two-week run with the following results:

Spanish

- Clicks: 90
- Reach: 3,562
- Impressions: 6,422

Filipino

- Clicks: 100
- Reach: 2,015
- Impressions: 4,685

Chinese

- Clicks: 81
- Reach: 1,837
- Impressions: 4,446

In total, the ads reached nearly 7,414 SoMa residents over the course of two weeks. The average cost-per-click across ads was about \$.55, which is standard for in-language survey ads. Overall, the ads were an effective way to expand the reach of the outreach effort to multilingual SoMa residents. On the organic side of social media, SFCTA posted the survey link and accompanying video on Facebook and Twitter. Agencies and groups like Vision Zero SF and SF Transit Riders reposted the survey link, expanding the reach of the survey to their networks.

Outreach to Community Organizations and Stakeholders

Members of the SFCTA project team and Civic Edge Consulting conducted outreach to nearly 70 organizations with connections to the project to solicit their feedback on how SoMa streets could be made safer for all that use them. These organizations, which include public agencies, community groups, local businesses and employers, and neighborhood and citywide advocacy groups were invited to share their experiences in SoMa through the survey and were given language promoting the survey to include in newsletters to their members.

The following is a list of organizations that were contacted about the SoMa Ramp Intersections Study either by email, phone, or both:

- 303 Second Street Plaza
- 33 Clementina St Home Owners Assn.
- Alliance for a Better District 6
- Bayanihan Community Center
- Bicycle Advisory Committee
- California Highway Patrol
- Canon Kip Senior Center
- Carmichael, Bessie (6-8 Campus)
- Carmichael, Bessie (Pre-K- 5 Campus)
- Central Market CBD
- Chinatown Community Development Center
- Coalition on Homelessness
- Community Awareness and Treatment Services, Inc - Women's Place drop-in clinic
- Courtyard by Marriott San Francisco Downtown

- Crafty Fox, Brick & Mortar*
- Department of Homelessness and Supportive Housing
- East Cut CBD
- Eastern Neighborhoods Citizen Advisory Committee
- Filipino American Development Foundation
- Filipino Cultural District
- Five Keys Charter School
- Flower Mart
- Gene Friend Rec Center
- Greek Orthodox Cathedral
- Hotel Council*
- Independent Living Resource Center
- Jasper San Francisco
- Livable City
- Lyon-Martin Health Services
- Market & Octavia CAC*
- Marshall Elementary School
- Mayor's Office on Disability (MOD)
- Natoma Neighborhood Group
- One Rincon Hill Association
- Police Officers Association
- Rincon Hill Residents Association
- Sailors' Union of the Pacific
- Salvation Army - Harbor Light
- San Francisco Bay Area and Planning and Urban Research Association (SPUR)
- San Francisco Bicycle Coalition*
- San Francisco Fire Department*
- San Francisco Police Department*
- San Francisco Sheriff's Dept
- San Francisco Tennis Club
- San Francisco Transit Riders
- Senior Disability Action
- SF Housing Authority/Mayor's Office of Housing and Community Development
- SFFD
- SFMTA Pedestrian Safety Advisory Committee (PSAC)
- SoMa Leadership Council
- SOMA Stabilization Fund
- SOMArts Cultural Center
- South Beach | Rincon | Mission Bay Neighborhood Association
- South Beach Merchants
- South of Market Business Association
- South of Market Community Action Network (SOMCAN)
- South of Market Youth Collaborative*
- Tenants and Owners Development Corporation (TODCO)
- Terra Gallery & Event Venue
- The Harrison
- The Stud Bar
- TMASF
- Transbay Joint Powers Authority (TJPA)
- Transbay Joint Powers Authority CAC*
- United Playaz
- Walk San Francisco*
- West Bay Filipino Multi Service Center
- West Bay Pilipino Multi Service Center
- Western SOMA Voice
- Western SoMa CBD
- Yerba Buena CBD

SFCTA made presentation to the organizations with asterisk (*)

The response from organizations was generally positive with a wide-ranging acknowledgment that the existing intersections are challenging to all street users, regardless if they are on foot or bicycle, taking transit, or driving. More specific feedback includes:

- Advanced traffic stop bar to increase distance between vehicles and pedestrians
- Rectangular Flashing Beacon signals (where applicable) to increase pedestrian awareness and visibility
- New crosswalks, bicycle lanes and sidewalks (where applicable) to reduce pedestrian and bicyclist crossing distance
- Pedestrian scale lighting under freeways to increase pedestrian and bicyclist visibility

- “No Turn on Red” signs to reduce vehicle turning speed and increase pedestrian visibility

Intercept Outreach in Collaboration with Vision Zero SF

To maximize participation by those who live and work in SoMa and those who travel through the area, the project team partnered with Vision Zero SF to conduct intercept outreach on May 2, 2018. Multilingual outreach ambassadors distributed the SoMa Ramps mailer along with VZSF informational materials. Ambassadors also engaged participants in an activity that asked them to rate their feeling of safety at the 10 ramp intersections.

A number of people shared stories of travelling in the area, including two who had been hit by a car at this intersection or similar intersections when biking or walking. While many individuals stated that they would take the online survey, there were a few recurring suggestions for improvements, including:

- Ensuring ADA compliant sidewalks (especially given the local populations of people with disabilities and experiencing homelessness);
- Improving drainage at these intersections so that they don't flood when it rains;
- Lengthening traffic signal pedestrian crossing times; and
- Improving the bus boarding island at Mission and 13th Street by addressing challenges like trash on the island and occasional tents which make it challenging to navigate.

Outreach Metrics:

- Number of interactions: 450
- Number of activity participants: 20
- SFCTA mailers distributed: 400
- Race (by observation): 30% White, 30% Asian and Pacific Islander, 30% Latino, 10% African American
- Age (by observation): 50% adults 25-50, 15% teens-early 20's, 5% under 12, 30% 50+
- Languages (by interactions): 70% English, 10% Spanish, 10% Chinese, 10% Filipino

Vision Zero SF also promoted SFCTA social media posts about the SoMa Ramp Intersections Study and survey.

APPENDIX E

Outreach Report Round 2



San Francisco
County Transportation
Authority

MEMO

To: SFCTA SoMa Ramps Project Team

From: Civic Edge Consulting, SFCTA Staff

Date: October 9, 2018

Subject: SoMa Ramp Intersections Safety Study – Round 2 Outreach Summary Report

The goal for the SoMa Ramp Intersections Safety Study's second round of outreach was to gather feedback on the draft safety improvement design proposals at ten freeway ramp intersections in the neighborhood. Outreach was centered around an open house but also included other methods such as stakeholder group meetings and tabling at Sunday Streets.

The second round of outreach included the following tools:

- Open house on July 31;
- Poster placement around the study's intersections (map);
- Intercept outreach in the study area, in collaboration with Vision Zero SF;
- Tabling at SoMa Sunday Streets on August 18; and
- Phone and email outreach to community-based organizations (CBOs), partner agencies, and other groups and individuals with an interest in the project.

Open House

The project team held an open house on Tuesday, July 31 from 5:30 to 7:30 p.m. at the Bayanihan Center at 1010 Mission Street. The event featured stations showing proposed designs at each of the ten study intersections, as well as information about the study background and potential next steps. Team members were available at each station to answer questions and a Filipino interpreter was on hand. Multilingual event notification materials invited participants to request any other needed translation or assistance services.

Open house attendees were asked to provide feedback through any of several mechanisms. Participants could use emoji stickers to identify design elements they did or did not like, add additional feedback on Post-It notes to be placed on the posters, and/or fill out comment cards with any more detailed input.

In total, 24 individuals signed in at the welcome station near the entrance to the Open House. A plurality of attendees cited an email from the SFCTA as the means by which they learned about the meeting. Another six individuals cited information from a community group.

Four individuals self-identified as "resident" or member of the "public," while another eight people listed no affiliation. All 12 of these individuals used personal emails, suggesting that they did not attend in any professional or organizational capacity. None of the participants needed translation services.



Two community non-profits were represented, with two individuals representing each South of Market Community Action Network (SOMCAN) and Senior Disability Action (SDA). Other individuals attended representing the Office of Supervisor Jane Kim, CalTrans, the San Francisco Bicycle Coalition, YIMBY Action, and SOMA West Community Benefit District.

Outreach to Community Organizations and Stakeholders

Members of the SFCTA project team and Civic Edge Consulting conducted outreach to nearly 70 organizations with connections to the project to solicit their feedback and invite them to the open house. These groups were the same as those contacted during the first round of outreach.

The following is a list of organizations that were contacted about the SoMa Ramp Intersections Study either by email, phone, or both (see next page). Based on stakeholder requests, project team members met with groups marked with an asterisk (*) during this round of outreach.

- 303 Second Street Plaza
- 33 Clementina St Home Owners Assn.
- Alliance for a Better District 6
- Bayanihan Community Center
- Bicycle Advisory Committee
- California Highway Patrol
- Canon Kip Senior Center
- Carmichael, Bessie (6-8 Campus)
- Carmichael, Bessie (Pre-K- 5 Campus)
- Central Market CBD
- Chinatown Community Development Center
- Coalition on Homelessness
- Community Awareness and Treatment Services, Inc - Women's Place drop-in clinic
- Courtyard by Marriott San Francisco Downtown
- Crafty Fox; Brick & Mortar
- Department of Homelessness and Supportive Housing
- East Cut CBD
- Eastern Neighborhoods Citizen Advisory Committee
- Filipino American Development Foundation
- Filipino Cultural District
- Five Keys Charter School
- Flower Mart
- Gene Friend Rec Center
- Greek Orthodox Cathedral
- Hotel Council
- Independent Living Resource Center
- Jasper San Francisco
- Livable City
- Lyon-Martin Health Services
- Market & Octavia CAC
- Marshall Elementary School
- Mayor's Office on Disability (MOD)*
- Natoma Neighborhood Group
- One Rincon Hill Association
- Police Officers Association
- Rincon Hill Residents Association
- Sailors' Union of the Pacific
- Salvation Army - Harbor Light
- San Francisco Bay Area and Planning and Urban Research Association (SPUR)
- San Francisco Bicycle Coalition*
- San Francisco Police Department
- San Francisco Sheriff's Dept
- San Francisco Tennis Club
- San Francisco Transit Riders
- Senior Disability Action
- SF Housing Authority/Mayor's Office of Housing and Community Development
- SFFD
- SFMTA Pedestrian Safety Advisory Committee (PSAC)
- SoMa Leadership Council
- SOMA Stabilization Fund
- SOMArts Cultural Center
- SoMaWest CBD
- South Beach | Rincon | Mission Bay Neighborhood Association
- South Beach Merchants
- South of Market Business Association
- South of Market Community Action Network (SOMCAN)
- Tenants and Owners Development Corporation (TODCO)
- Terra Gallery & Event Venue
- The Harrison
- The Stud Bar
- TMA SF
- Transbay Joint Powers Authority (TJPA)
- Transbay Joint Powers Authority CAC
- United Playaz
- Walk San Francisco*
- West Bay Filipino Multi Service Center
- West Bay Pilipino Multi Service Center
- West SoMa Community Benefits District*
- Western SOMA Voice
- Yerba Buena CBD

Intercept Outreach

In conjunction with Vision Zero SF, our team conducted intercept outreach on July 26 from 3 to 7 PM at 7th and Bryant outside of the Hall of Justice. Three Outreach Ambassadors, who between them spoke English, Spanish, Chinese, and Filipino, interacted with 250 individuals representing a diverse cross-section of people walking in the neighborhood.

The team focused on informing individuals about the upcoming SoMa Ramps Study Open House. The majority of people we talked to were happy to receive a flyer about the Open House. About 30 people were eager to stop and find out more information, including where the Open House would take place and what specific recommendations were going to be outlined by the project team. About ten people we spoke to told us that they had already heard of the Open House and three people indicated that they were going to attend.

People were generally very happy to hear that both the SoMa Ramps Study and Open House were taking place. Most people told us that the SoMa neighborhood feels very unsafe due to high traffic volumes, high speeds, and distracted driving. Tabling at the corner of 7th and Bryant was a powerful tool, as pedestrians were able to directly point out nearby freeway ramps and indicate the challenges happening “right here.” Individuals have seen collisions happen themselves in this neighborhood and welcome this focus on improving safety.

Sunday Streets Outreach

Sunday Streets is a public event held by SFMTA and Livable City to promote active urban lifestyles, centering on bicycle and pedestrian activities. In coordination with Vision Zero SF, the SFCTA team and a representative from SFMTA hosted interactive outreach boards and collected feedback on proposed improvements to the ten study intersections. The boards themselves covered the project overview and displayed illustrative renderings of the draft proposed improvements.

In total, the team interacted with approximately 160 individuals, many whom left feedback emoji stickers on the posters indicating whether they liked or did not like the proposed improvements. Overall, people were happy to see safety improvements being planned. In addition, nine individuals signed up for the email list and seven individuals left specific comments on feedback cards.

Posters and other Notifications

Several additional methods were used to distribute notifications announcing the availability of design recommendations and the time and location of the open house. Posters in English, Chinese, Spanish, and Filipino were placed throughout SoMa near the ten intersections included in this study. Posters were placed within one to two blocks of the study intersections and numbered nearly 90 in total. Posters were removed within two days of the Open House. Notification emails were sent to the nearly 450 people who had indicated interest in the study during the first round of outreach, including recipients of first-round radius mailer postcards and respondents to the survey conducted earlier in the year. Lastly, social media posts also advertised the upcoming outreach.

Feedback Overview

The project team compiled public feedback collected during this outreach round and used it to further refine and improve the proposals for the ten ramp intersections. In addition, some feedback was more general than can be addressed by focusing on the designs for these intersections alone, such as requests for more traffic enforcement or street and freeway network changes that extend beyond the study intersections. These ideas were shared with appropriate agencies and teams (e.g. SFMTA for traffic enforcement requests and the Connect SF planning process to study larger transportation network changes). Feedback received included the following summarized comments:

Pedestrian crossings:

- Shorter and wider crosswalks
- Concerns regarding pedestrian crossing lengths with the two-way Otis St. design
- Improve pedestrian signal visibility
- Replace or augment yield signs on unsignalized off-ramps with more signage, flashing lights, stop signs, and/or full signals
- More curb bulb-outs and improve visibility with paint
- More "No Right on Red" signs
- More leading pedestrian signals and longer pedestrian walking times
- Add painted stop lines in advance of crosswalks

Bicycle infrastructure:

- More protected bike lanes (consider using planters for protection in the long term)
- More bike-specific signals
- More bike lanes fully delineated through intersections
- Refine design of merge areas between bikes and turning cars
- At mid-block crossings, more signs warning bicyclists to slow down

Transit:

- Bus shelter shade improvements and arrival time indicators
- More dedicated Muni lanes

Accessibility:

- Improve accessibility to bus stop islands with more curb ramps or raised crosswalks
- Accessible Pedestrian Signals (APS) at all intersections
- Maintain blue parking zones when reducing parking spaces
- Maintain curb access where needed when installing bike lanes

Auto:

- Create sharper turns to slow down vehicles, especially coming from freeway ramps
- Maintain vehicle access to businesses (e.g. Discount Builder and Supply Store on Mission)
- More road diets to reduce auto lanes
- More traffic enforcement
- Long term elimination of freeways and on-off ramps

General/Other:

- Improve intersection lighting, especially below underpasses
- More street greenery, especially on medians, and placemaking elements
- More active TDM programs

APPENDIX F

Full Cost Estimates



San Francisco
County Transportation
Authority

Location:	MISSION STREET/13TH STREET/US 101 NB OFF-RAMP				
NEAR-TERM					
#	Description	QTY	Unit	Unit Cost	Total Cost
N1	Bus Only Lane Striping	1200	Per SQ FT of Red Lane	\$ 20	\$ 24,000
N2	Pavement Markings (Intersection)	2	Each Intersection	\$ 10,000	\$ 20,000
N3	Remove/Replace Signs	3	Per Sign	\$ 300	\$ 900
N4	Temporary Bulb-out/Refuge (with delineators)	1	EA	\$ 10,000	\$ 10,000
				Total	\$ 54,900
CAPITAL					
#	Description	QTY	Unit	Unit Cost	Total Cost
C1	Accessible Pedestrian Signals	2	Per Intersection	\$ 200,000	\$ 400,000
C2	Bulb-out	3	EA	\$ 113,000	\$ 339,000
C3	Pavement Markings (Intersection)	2	Each Intersection	\$ 10,000	\$ 20,000
C4	Raised Median	3	EA	\$ 23,000	\$ 69,000
C5	Remove/Replace Signs	1	Per Sign	\$ 300	\$ 300
C6	RRFB Assembly	1	LS	\$ 200,000	\$ 200,000
C7	Traffic Signals (12" section) [Install/upgrade]	2	Each Signal Head	\$ 5,000	\$ 10,000
C8	Traffic Signals (12" section) and a new Pole	1	EA	\$ 25,000	\$ 25,000
				Total	\$ 1,063,300
Location:	SOUTH VAN NESS AVE/13TH ST/US 101 SB ON-RAMP				
NEAR-TERM					
#	Description	QTY	Unit	Unit Cost	Total Cost
N1	Pavement Markings (Intersection)	1	Each Intersection	\$ 10,000	\$ 10,000
N2	Remove/Replace Signs	3	Per Sign	\$ 300	\$ 900
N3	Temporary Bulb-out/Refuge (with delineators)	1	EA	\$ 10,000	\$ 10,000
				Total	\$ 20,900
CAPITAL					
#	Description	QTY	Unit	Unit Cost	Total Cost
C1	12" Backplates	1	Per Intersection	\$ 5,000	\$ 5,000
C2	Accessible Pedestrian Signals	1	Per Intersection	\$ 200,000	\$ 200,000
C3	Bulb-out	1	EA	\$ 113,000	\$ 113,000
C4	Overhead Sign	1	EA	\$ 52,000	\$ 52,000
C5	Pedestrian Crossing With Signals	1	EA	\$ 400,000	\$ 400,000
C6	Raised Median	3	EA	\$ 23,000	\$ 69,000
C7	Sidewalk	1	LS	\$ 62,000	\$ 62,000
C8	Traffic Signals (12" section) and a new Pole	7	EA	\$ 25,000	\$ 175,000
				Total	\$ 1,076,000
Location:	8TH STREET (MIDBLOCK)/I-80 WB OFF-RAMP				
NEAR-TERM					
#	Description	QTY	Unit	Unit Cost	Total Cost
N1	Pavement Markings (Intersection)	1	Each Intersection	\$ 10,000	\$ 10,000
				Total	\$ 10,000
CAPITAL					
#	Description	QTY	Unit	Unit Cost	Total Cost
C1	Bulb-out	1	EA	\$ 113,000	\$ 113,000
C2	Crosswalk Striping (Continental)	1	EA Intersection	\$ 5,000	\$ 5,000
C3	Pavement Markings (Intersection)	1	Each Intersection	\$ 10,000	\$ 10,000
C4	RRFB Assembly	1	LS	\$ 200,000	\$ 200,000
Total				Total	\$ 328,000

Location:	BRYANT STREET/8TH STREET/I-80 EB ON-RAMP					
NEAR-TERM						
#	Description	QTY	Unit	Unit Cost	Total Cost	
N1	Green Bike Crossing	120	SQFT	\$ 20	\$ 2,400	
N2	Pavement Markings (Intersection)	1	Each Intersection	\$ 10,000	\$ 10,000	
N3	Remove/Replace Signs	2	Per Sign	\$ 300	\$ 600	
N4	Temporary Bulb-out/Refuge (with delineators)	2	EA	\$ 10,000	\$ 20,000	
N5	Install Leading Pedestrian Interval	1	LS	\$ 4,000	\$ 4,000	
Total				Total	\$ 37,000	
CAPITAL						
#	Description	QTY	Unit	Unit Cost	Total Cost	
C1	Accessible Pedestrian Signals	2	Per Intersection	\$ 200,000	\$ 400,000	
C2	Bulb-out	4	EA	\$ 113,000	\$ 452,000	
C3	Mast Arm Pole with signals	1	Each Pole	\$ 71,000	\$ 71,000	
C4	Overhead Sign	2	EA	\$ 52,000	\$ 104,000	
C5	Pavement Markings (Intersection)	1	Each Intersection	\$ 10,000	\$ 10,000	
C6	Pedestrian Crossing With Signals	2	EA	\$ 400,000	\$ 800,000	
C7	Sidewalk	1	LS	\$ 62,000	\$ 62,000	
C8	Traffic Signals (12" section) and a new Pole	5	EA	\$ 25,000	\$ 125,000	
				Total	\$ 2,024,000	
Location:	HARRISON STREET/7TH STREET/I-80 WB ON-RAMP					
NEAR-TERM						\$ 10,000
#	Description	QTY	Unit	Unit Cost	Total Cost	
N1	Pavement Markings (Intersection)	1	Each Intersection	\$ 10,000	\$ 10,000	
Total					\$ 10,000	
CAPITAL						
#	Description	QTY	Unit	Unit Cost	Total Cost	
C1	Accessible Pedestrian Signals	1	Per Intersection	\$ 200,000	\$ 200,000	
C2	Bulb-out	5	EA	\$ 113,000	\$ 565,000	
C3	Crosswalk Striping (Continental)	1	EA Intersection	\$ 5,000	\$ 5,000	
C4	Pedestrian Crossing With Signals	1	EA	\$ 400,000	\$ 400,000	
C5	Raised Median	2	EA	\$ 23,000	\$ 46,000	
C6	Traffic Signals (12" section) and a new Pole	2	EA	\$ 25,000	\$ 50,000	
Total					\$ 1,266,000	
Location:	7TH STREET (MIDBLOCK)/I-80 EB OFF-RAMP VISION					
NEAR-TERM						
#	Description	QTY	Unit	Unit Cost	Total Cost	
N1	Pavement Markings (Intersection)	1	Each Intersection	\$ 10,000	\$ 10,000	
N2	Remove/Replace Signs	5	Per Sign	\$ 300	\$ 1,500	
Total					\$ 11,500	
CAPITAL						
#	Description	QTY	Unit	Unit Cost	Total Cost	
C1	Bulb-out	2	EA	\$ 113,000	\$ 226,000	
C2	Crosswalk Striping (Continental)	1	EA Intersection	\$ 5,000	\$ 5,000	
C3	Pavement Markings (Intersection)	1	Each Intersection	\$ 10,000	\$ 10,000	
C4	RRFB Assembly	1	LS	\$ 200,000	\$ 200,000	
Total					\$ 441,000	

Location:	BRYANT STREET/7TH STREET/I-80 EB OFF-RAMP				
NEAR-TERM					
#	Description	QTY	Unit	Unit Cost	Total Cost
N1	Crosswalk Striping (Continental)	1	EA Intersection	\$ 5,000	\$ 5,000
N2	Green Bike Crossing	180	SQFT	\$ 20	\$ 3,600
N3	Temporary Bulb-out/Refuge (with delineators)	3	EA	\$ 10,000	\$ 30,000
Total					\$ 38,600
CAPITAL					
#	Description	QTY	Unit	Unit Cost	Total Cost
C1	Accessible Pedestrian Signals	1	Per Intersection	\$ 200,000	\$ 200,000
C2	Bulb-out	6	EA	\$ 113,000	\$ 678,000
C3	Mast Arm Pole with signals	2	Each Pole	\$ 71,000	\$ 142,000
C4	Raised Median	1	EA	\$ 23,000	\$ 23,000
C5	Traffic Signals (12" section) and a new Pole	2	EA	\$ 25,000	\$ 50,000
Total					\$ 1,093,000
Location:	BRANNAN STREET/6TH STREET/I-280 ON/OFF-RAMP				
NEAR-TERM					
#	Description	QTY	Unit	Unit Cost	Total Cost
N1	12" Backplates	1	Per Intersection	\$ 5,000	\$ 5,000
N2	Crosswalk Striping (Continental)	1	EA Intersection	\$ 5,000	\$ 5,000
N3	Install Leading Pedestrian Interval	1	LS	\$ 4,000	\$ 4,000
N4	Pavement Markings (Intersection)	1	Each Intersection	\$ 10,000	\$ 10,000
N6	Remove/Replace Signs	1	Per Sign	\$ 300	\$ 300
N7	Traffic Signals (12" section) [Install/upgrade]	5	Each Signal Head	\$ 5,000	\$ 25,000
Total					\$ 49,300
CAPITAL					
#	Description	QTY	Unit	Unit Cost	Total Cost
C1	Accessible Pedestrian Signals	1	Per Intersection	\$ 200,000	\$ 200,000
C2	Bulb-out	3	EA	\$ 113,000	\$ 339,000
C3	Crosswalk Striping (Continental)	1	EA Intersection	\$ 5,000	\$ 5,000
C4	Pedestrian Crossing With Signals	1	EA	\$ 400,000	\$ 400,000
C5	Raised Median	2	EA	\$ 23,000	\$ 46,000
C6	Remove/Replace Signs	2	Per Sign	\$ 300	\$ 600
C7	Traffic Signals (12" section) and a new Pole	5	EA	\$ 25,000	\$ 125,000
Total					\$ 1,115,600
Location:	HARRISON STREET/ESSEX STREET/I-80 EB ON-RAMP				
NEAR-TERM					
#	Description	QTY	Unit	Unit Cost	Total Cost
N1	Crosswalk Striping (Continental)	1	EA Intersection	\$ 5,000	\$ 5,000
N2	Install Leading Pedestrian Interval	1	LS	\$ 4,000	\$ 4,000
Total					\$ 9,000
CAPITAL					
#	Description	QTY	Unit	Unit Cost	Total Cost
C1	Accessible Pedestrian Signals	1	Per Intersection	\$ 200,000	\$ 200,000
C2	Mast Arm Pole with signals	2	Each Pole	\$ 71,000	\$ 142,000
C3	Pavement Markings (Intersection)	1	Each Intersection	\$ 10,000	\$ 10,000
C4	Pedestrian Crossing With Signals	2	EA	\$ 400,000	\$ 800,000
C5	Remove/Replace Signs	2	Per Sign	\$ 300	\$ 600
C6	Retaining Wall	1	LS	\$ 353,000	\$ 353,000
C7	Sidewalk	1	LS	\$ 62,000	\$ 62,000
C8	Traffic Signals (12" section) and a new Pole	2	EA	\$ 25,000	\$ 50,000
Total					\$ 1,617,600

Location:	FREMONT STREET/I-80 WB OFF-RAMP VISION ZERO				
NEAR-TERM					
#	Description	QTY	Unit	Unit Cost	Total Cost
N1	Crosswalk Striping (Continental)	1	EA Intersection	\$ 5,000	\$ 5,000
N2	Remove/Replace Signs	2	Per Sign	\$ 300	\$ 600
Total					\$ 5,600
CAPITAL					
#	Description	QTY	Unit	Unit Cost	Total Cost
C1	Curb Ramp	2	Per Corner (2 ramps)	\$ 23,000	\$ 46,000
C2	Pedestrian Crossing With Signals	1	EA	\$ 400,000	\$ 400,000
C3	Raised Median	1	EA	\$ 23,000	\$ 23,000
Total					\$ 469,000

APPENDIX G

Traffic Counts



San Francisco
County Transportation
Authority

TRAFFIC COUNTS PLUS

mietekm@comcast.net
925.305.4358

CITY OF SAN FRANCISCO

Latitude: 37.77470
Longitude: -122.405403

File Name : 7-80 eb off-ramp-a

Site Code : 2
Start Date : 8/28/2018
Page No : 1

Groups Printed- Vehicles Only

Start Time	7th ST Southbound				0 Westbound				7th ST Northbound				I-80 EB OFF-RAMP Eastbound				Int. Total
	RT	TH	LT	App. Total	RT	TH	LT	App. Total	RT	TH	LT	App. Total	RT	TH	LT	App. Total	
07:00	0	0	0	0	0	0	0	0	0	128	0	128	0	0	149	149	277
07:15	0	0	0	0	0	0	0	0	0	130	0	130	0	0	161	161	291
07:30	0	0	0	0	0	0	0	0	0	160	0	160	0	0	159	159	319
07:45	0	0	0	0	0	0	0	0	0	203	0	203	0	0	175	175	378
Total	0	0	0	0	0	0	0	0	0	621	0	621	0	0	644	644	1265
08:00	0	0	0	0	0	0	0	0	0	190	0	190	0	0	166	166	356
08:15	0	0	0	0	0	0	0	0	0	224	0	224	0	0	189	189	413
08:30	0	0	0	0	0	0	0	0	0	228	0	228	0	0	184	184	412
08:45	0	0	0	0	0	0	0	0	0	214	0	214	0	0	197	197	411
Total	0	0	0	0	0	0	0	0	0	856	0	856	0	0	736	736	1592
Grand Total	0	0	0	0	0	0	0	0	0	1477	0	1477	0	0	1380	1380	2857
Apprch %	0	0	0	0	0	0	0	0	0	100	0	100	0	0	100	100	
Total %	0	0	0	0	0	0	0	0	0	51.7	0	51.7	0	0	48.3	48.3	

Start Time	7th ST Southbound				0 Westbound				7th ST Northbound				I-80 EB OFF-RAMP Eastbound				Int. Total
	RT	TH	LT	App. Total	RT	TH	LT	App. Total	RT	TH	LT	App. Total	RT	TH	LT	App. Total	
08:00	0	0	0	0	0	0	0	0	0	190	0	190	0	0	166	166	356
08:15	0	0	0	0	0	0	0	0	0	224	0	224	0	0	189	189	413
08:30	0	0	0	0	0	0	0	0	0	228	0	228	0	0	184	184	412
08:45	0	0	0	0	0	0	0	0	0	214	0	214	0	0	197	197	411
Total Volume	0	0	0	0	0	0	0	0	0	856	0	856	0	0	736	736	1592
% App. Total	0	0	0	0	0	0	0	0	0	100	0	100	0	0	100	100	
PHF	.000	.000	.000	.000	.000	.000	.000	.000	.000	.939	.000	.939	.000	.000	.934	.934	.964

Peak Hour Analysis From 07:00 to 08:45 - Peak 1 of 1

Peak Hour for Entire Intersection Begins at 08:00

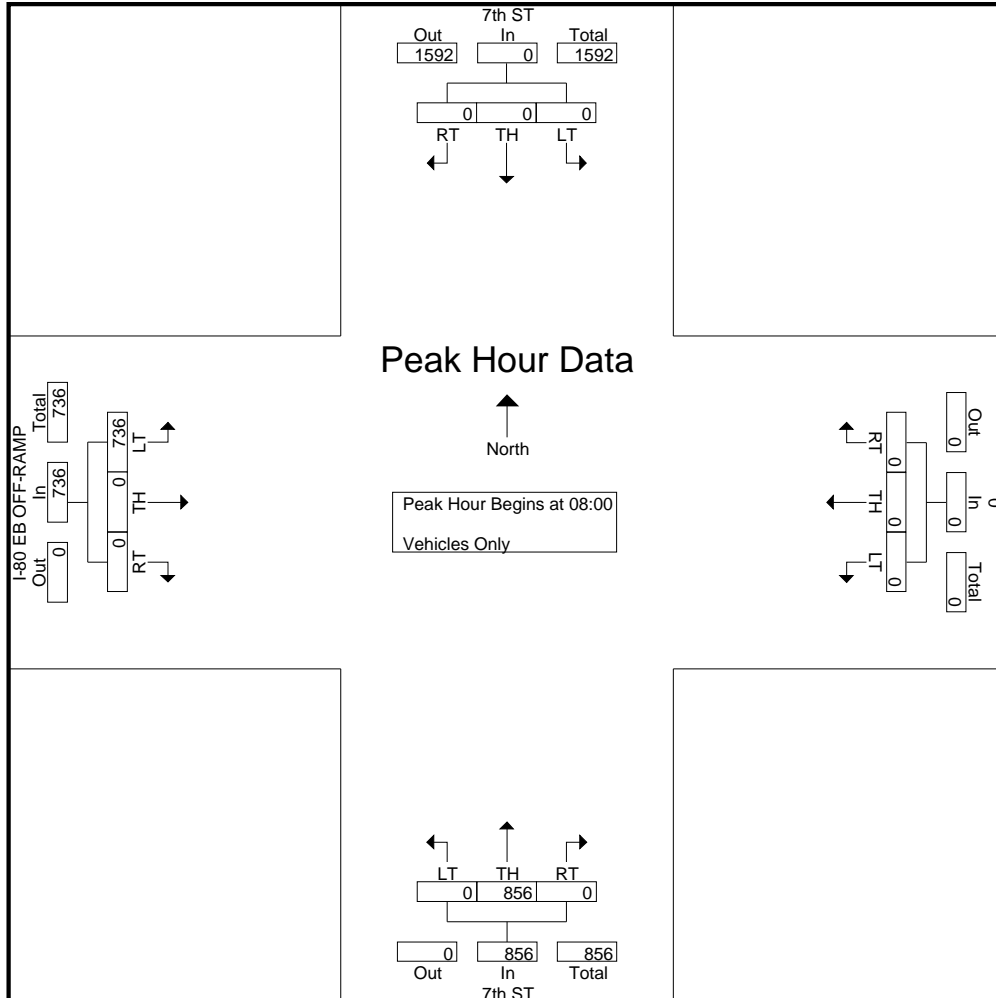

TRAFFIC COUNTS PLUS

mietekm@comcast.net
925.305.4358

CITY OF SAN FRANCISCO

Latitude: 37.77470
Longitude: -122.405403

File Name : 7-80 EB off-ramp-p

Site Code : 2
Start Date : 8/28/2018
Page No : 1

Groups Printed- Vehicles Only

Start Time	7th ST Southbound				0 Westbound				7th ST Northbound				I-80 EB OFF-RAMP Eastbound				Int. Total
	RT	TH	LT	App. Total	RT	TH	LT	App. Total	RT	TH	LT	App. Total	RT	TH	LT	App. Total	
16:00	0	0	0	0	0	0	0	0	0	307	0	307	0	0	25	25	332
16:15	0	0	0	0	0	0	0	0	0	288	0	288	0	0	26	26	314
16:30	0	0	0	0	0	0	0	0	0	306	0	306	0	0	24	24	330
16:45	0	0	0	0	0	0	0	0	0	324	0	324	0	0	33	33	357
Total	0	0	0	0	0	0	0	0	0	1225	0	1225	0	0	108	108	1333
17:00	0	0	0	0	0	0	0	0	0	336	0	336	0	0	36	36	372
17:15	0	0	0	0	0	0	0	0	0	338	0	338	0	0	51	51	389
17:30	0	0	0	0	0	0	0	0	0	340	0	340	0	0	51	51	391
17:45	0	0	0	0	0	0	0	0	0	305	0	305	0	0	72	72	377
Total	0	0	0	0	0	0	0	0	0	1319	0	1319	0	0	210	210	1529
Grand Total	0	0	0	0	0	0	0	0	0	2544	0	2544	0	0	318	318	2862
Apprch %	0	0	0	0	0	0	0	0	0	100	0	100	0	0	100	100	
Total %	0	0	0	0	0	0	0	0	0	88.9	0	88.9	0	0	11.1	11.1	

Start Time	7th ST Southbound				0 Westbound				7th ST Northbound				I-80 EB OFF-RAMP Eastbound				Int. Total
	RT	TH	LT	App. Total	RT	TH	LT	App. Total	RT	TH	LT	App. Total	RT	TH	LT	App. Total	
17:00	0	0	0	0	0	0	0	0	0	336	0	336	0	0	36	36	372
17:15	0	0	0	0	0	0	0	0	0	338	0	338	0	0	51	51	389
17:30	0	0	0	0	0	0	0	0	0	340	0	340	0	0	51	51	391
17:45	0	0	0	0	0	0	0	0	0	305	0	305	0	0	72	72	377
Total Volume	0	0	0	0	0	0	0	0	0	1319	0	1319	0	0	210	210	1529
% App. Total	0	0	0	0	0	0	0	0	0	100	0	100	0	0	100	100	
PHF	.000	.000	.000	.000	.000	.000	.000	.000	.000	.970	.000	.970	.000	.000	.729	.729	.978

Peak Hour Analysis From 16:00 to 17:45 - Peak 1 of 1

Peak Hour for Entire Intersection Begins at 17:00

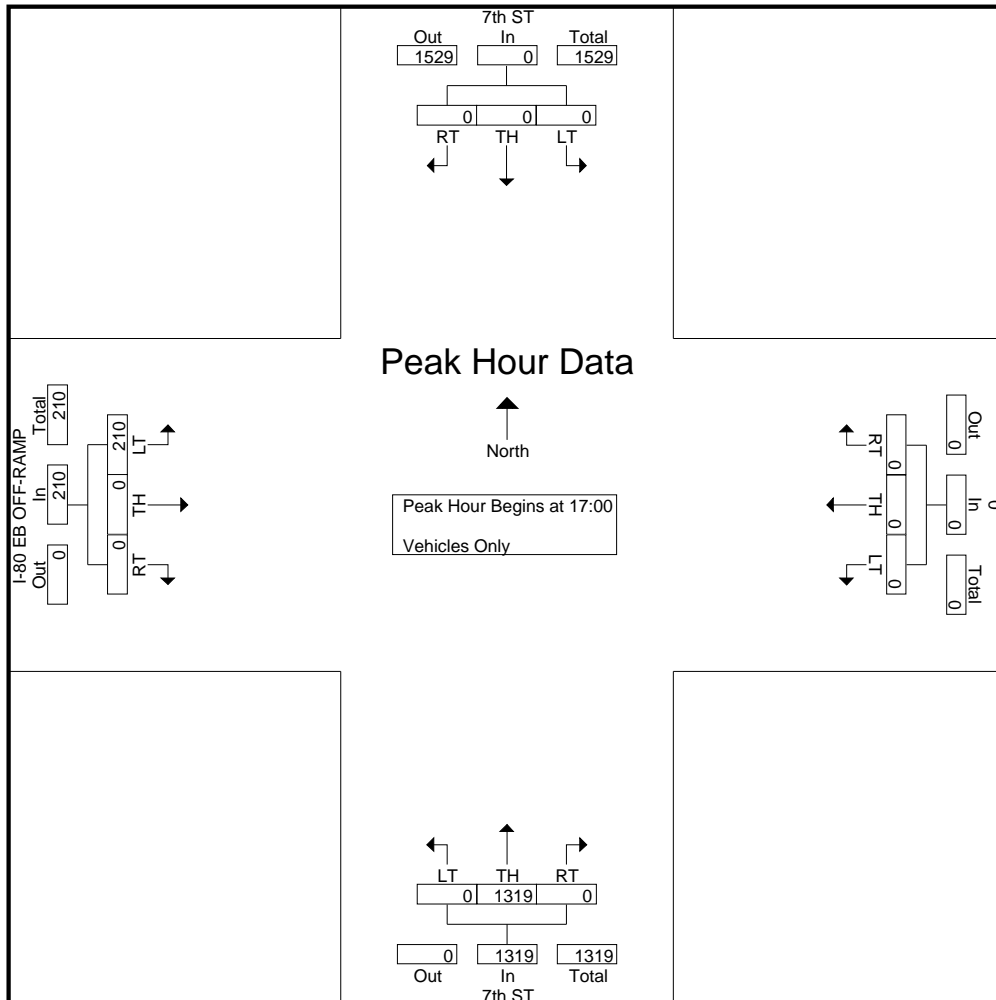

TRAFFIC COUNTS PLUS

mietekm@comcast.net
925.305.4358

CITY OF SAN FRANCISCO

Latitude: 37.774300
Longitude: -122.404762

File Name : 7-bryant-a
Site Code : 1
Start Date : 8/28/2018
Page No : 1

Groups Printed- Vehicles Only

Start Time	7th ST Southbound				BRYANT ST Westbound				7th ST Northbound				BRYANT ST Eastbound				I-80 EB OFF-RAMP Southeastbound				Int. Total
	RT	TH	LT	App. Total	RT	TH	LT	App. Total	RT	TH	LT	App. Total	RT	TH	LT	App. Total	RT	TH	LT	App. Total	
07:00	0	0	0	0	0	0	0	0	33	105	0	138	0	70	22	92	0	45	3	48	278
07:15	0	0	0	0	0	0	0	0	35	117	0	152	0	99	22	121	0	59	2	61	334
07:30	0	0	0	0	0	0	0	0	38	136	0	174	0	116	26	142	0	58	0	58	374
07:45	0	0	0	0	0	0	0	0	29	173	0	202	0	142	29	171	0	82	0	82	455
Total	0	0	0	0	0	0	0	0	135	531	0	666	0	427	99	526	0	244	5	249	1441
08:00	0	0	0	0	0	0	0	0	38	152	0	190	0	132	37	169	0	87	1	88	447
08:15	0	0	0	0	0	0	0	0	46	178	0	224	0	177	45	222	0	116	1	117	563
08:30	0	0	0	0	0	0	0	0	38	176	0	214	0	168	46	214	0	153	0	153	581
08:45	0	0	0	0	0	0	0	0	47	179	0	226	0	196	42	238	0	159	5	164	628
Total	0	0	0	0	0	0	0	0	169	685	0	854	0	673	170	843	0	515	7	522	2219
Grand Total	0	0	0	0	0	0	0	0	304	1216	0	1520	0	1100	269	1369	0	759	12	771	3660
Apprch %	0	0	0	0	0	0	0	0	20	80	0	41.5	0	80.4	19.6	37.4	0	98.4	1.6	21.1	
Total %	0	0	0	0	0	0	0	0	8.3	33.2	0	41.5	0	30.1	7.3	37.4	0	20.7	0.3	21.1	

Start Time	7th ST Southbound				BRYANT ST Westbound				7th ST Northbound				BRYANT ST Eastbound				I-80 EB OFF-RAMP Southeastbound				Int. Total
	RT	TH	LT	App. Total	RT	TH	LT	App. Total	RT	TH	LT	App. Total	RT	TH	LT	App. Total	RT	TH	LT	App. Total	
Peak Hour Analysis From 07:00 to 08:45 - Peak 1 of 1																					
Peak Hour for Entire Intersection Begins at 08:00																					
08:00	0	0	0	0	0	0	0	0	38	152	0	190	0	132	37	169	0	87	1	88	447
08:15	0	0	0	0	0	0	0	0	46	178	0	224	0	177	45	222	0	116	1	117	563
08:30	0	0	0	0	0	0	0	0	38	176	0	214	0	168	46	214	0	153	0	153	581
08:45	0	0	0	0	0	0	0	0	47	179	0	226	0	196	42	238	0	159	5	164	628
Total Volume	0	0	0	0	0	0	0	0	169	685	0	854	0	673	170	843	0	515	7	522	2219
% App. Total	0	0	0	0	0	0	0	0	19.8	80.2	0	41.5	0	79.8	20.2	37.4	0	98.7	1.3	21.1	
PHF	.000	.000	.000	.000	.000	.000	.000	.000	.899	.957	.000	.945	.000	.858	.924	.886	.000	.810	.350	.796	.883

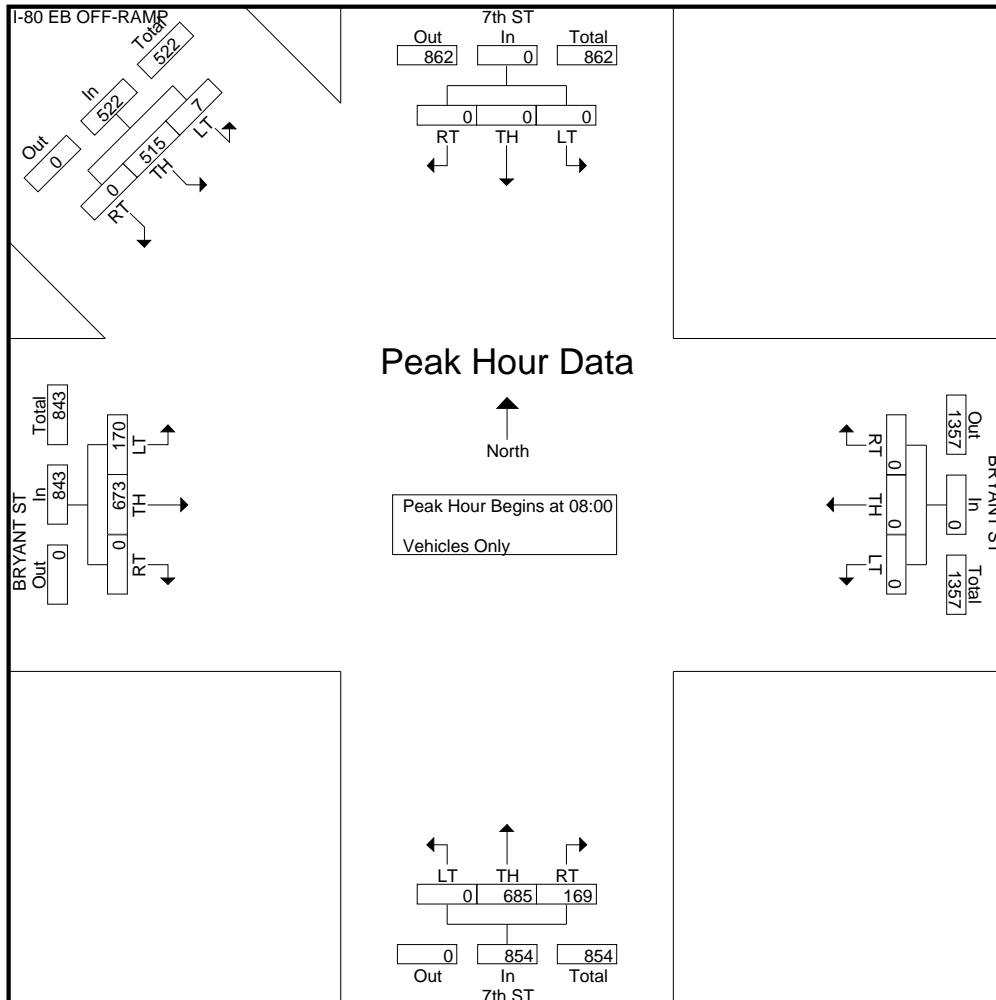

TRAFFIC COUNTS PLUS

mietekm@comcast.net
925.305.4358

CITY OF SAN FRANCISCO

Latitude: 37.774300
Longitude: -122.404762

File Name : 7-bryant-p
Site Code : 1
Start Date : 8/28/2018
Page No : 1

Groups Printed- Vehicles Only

Start Time	7th ST Southbound				BRYANT ST Westbound				7th ST Northbound				BRYANT ST Eastbound				I-80 EB OFF-RAMP Southeastbound				Int. Total
	RT	TH	LT	App. Total	RT	TH	LT	App. Total	RT	TH	LT	App. Total	RT	TH	LT	App. Total	RT	TH	LT	App. Total	
16:00	0	0	0	0	0	0	0	0	54	254	0	308	0	156	57	213	0	20	1	21	542
16:15	0	0	0	0	0	0	0	0	55	238	0	293	0	178	51	229	0	25	0	25	547
16:30	0	0	0	0	0	0	0	0	64	258	0	322	0	170	50	220	0	25	0	25	567
16:45	0	0	0	0	0	0	0	0	54	266	0	320	0	165	57	222	0	33	0	33	575
Total	0	0	0	0	0	0	0	0	227	1016	0	1243	0	669	215	884	0	103	1	104	2231
17:00	0	0	0	0	0	0	0	0	69	278	0	347	0	187	65	252	0	31	0	31	630
17:15	0	0	0	0	0	0	0	0	60	268	0	328	0	248	73	321	0	22	0	22	671
17:30	0	0	0	0	0	0	0	0	50	257	0	307	0	283	79	362	0	44	0	44	713
17:45	0	0	0	0	0	0	0	0	51	246	0	297	0	209	63	272	0	51	2	53	622
Total	0	0	0	0	0	0	0	0	230	1049	0	1279	0	927	280	1207	0	148	2	150	2636
Grand Total	0	0	0	0	0	0	0	0	457	2065	0	2522	0	1596	495	2091	0	251	3	254	4867
Apprch %	0	0	0	0	0	0	0	0	18.1	81.9	0	51.8	0	76.3	23.7	43	0	98.8	1.2	5.2	
Total %	0	0	0	0	0	0	0	0	9.4	42.4	0	51.8	0	32.8	10.2	43	0	5.2	0.1	5.2	

Start Time	7th ST Southbound				BRYANT ST Westbound				7th ST Northbound				BRYANT ST Eastbound				I-80 EB OFF-RAMP Southeastbound				Int. Total
	RT	TH	LT	App. Total	RT	TH	LT	App. Total	RT	TH	LT	App. Total	RT	TH	LT	App. Total	RT	TH	LT	App. Total	
Peak Hour Analysis From 16:00 to 17:45 - Peak 1 of 1																					
Peak Hour for Entire Intersection Begins at 17:00																					
17:00	0	0	0	0	0	0	0	0	69	278	0	347	0	187	65	252	0	31	0	31	630
17:15	0	0	0	0	0	0	0	0	60	268	0	328	0	248	73	321	0	22	0	22	671
17:30	0	0	0	0	0	0	0	0	50	257	0	307	0	283	79	362	0	44	0	44	713
17:45	0	0	0	0	0	0	0	0	51	246	0	297	0	209	63	272	0	51	2	53	622
Total Volume	0	0	0	0	0	0	0	0	230	1049	0	1279	0	927	280	1207	0	148	2	150	2636
% App. Total	0	0	0	0	0	0	0	0	18	82	0	51.8	0	76.8	23.2	43	0	98.7	1.3	5.2	
PHF	.000	.000	.000	.000	.000	.000	.000	.000	.833	.943	.000	.921	.000	.819	.886	.834	.000	.725	.250	.708	.924

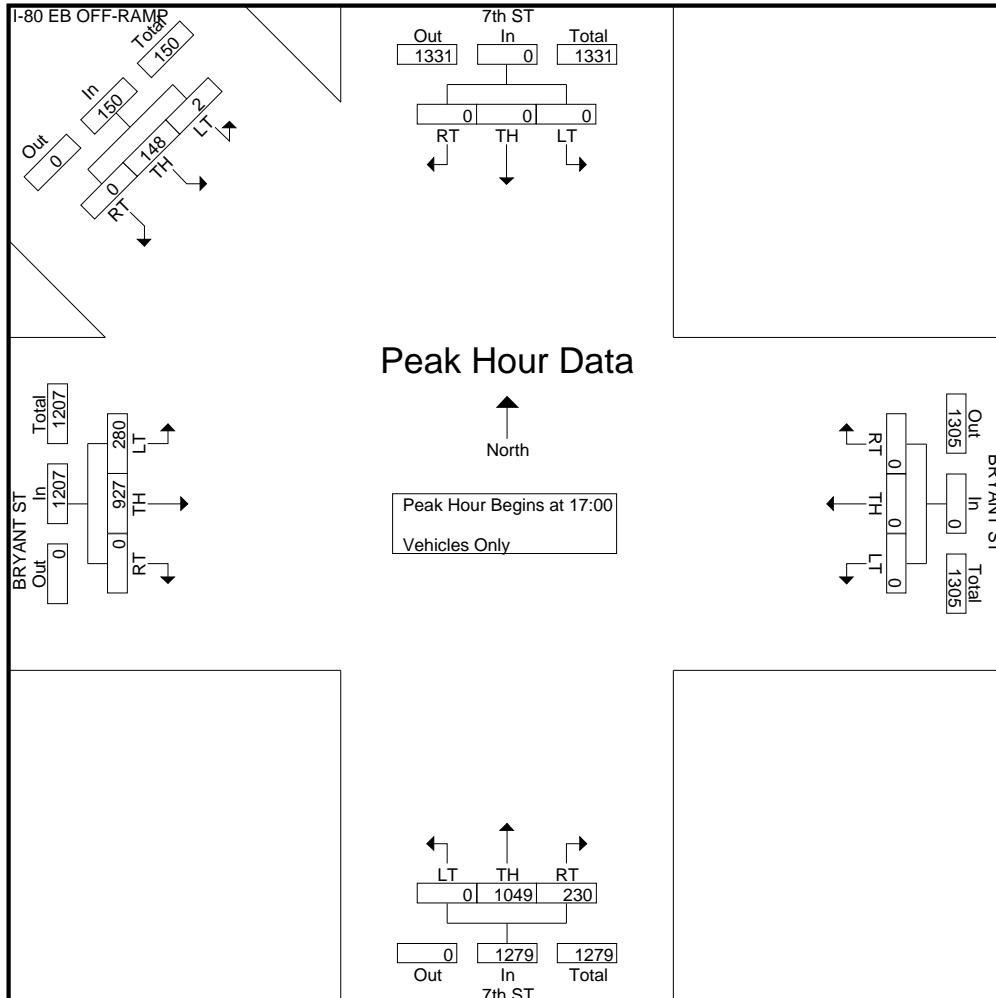

TRAFFIC COUNTS PLUS

mietekm@comcast.net
925.305.4358

CITY OF SAN FRANCISCO

Latitude: 37.775525
Longitude: -122.406314

File Name : 7-harrison-a
Site Code : 3
Start Date : 8/28/2018
Page No : 1

Groups Printed- Vehicles Only

Start Time	7th ST Southbound				HARRISON ST Westbound					7th ST Northbound					HARRISON ST Eastbound				I-80 EB ON-RAMP Northeastbound				Int. Total	
	RT	TH	LT	App. Total	RT	TH	to I-80	LT	App. Total	RT	TH	LT	to I-80	App. Total	RT	TH	LT	App. Total	RT	TH	LT	App. Total		
07:00	0	0	0	0	65	79	66	0	210	0	238	19	18	275	0	0	0	0	0	0	0	0	0	485
07:15	0	0	0	0	68	91	53	0	212	0	245	21	12	278	0	0	0	0	0	0	0	0	0	490
07:30	0	0	0	0	62	100	58	0	220	0	255	15	17	287	0	0	0	0	0	0	0	0	0	507
07:45	0	0	0	0	84	113	92	0	289	0	292	25	20	337	0	0	0	0	0	0	0	0	0	626
Total	0	0	0	0	279	383	269	0	931	0	1030	80	67	1177	0	0	0	0	0	0	0	0	0	2108
08:00	0	0	0	0	84	98	71	0	253	0	293	20	11	324	0	0	0	0	0	0	0	0	0	577
08:15	0	0	0	0	79	110	90	0	279	0	313	34	28	375	0	0	0	0	0	0	0	0	0	654
08:30	0	0	0	0	68	129	104	0	301	0	305	32	25	362	0	0	0	0	0	0	0	0	0	663
08:45	0	0	0	0	75	121	118	0	314	0	312	48	20	380	0	0	0	0	0	0	0	0	0	694
Total	0	0	0	0	306	458	383	0	1147	0	1223	134	84	1441	0	0	0	0	0	0	0	0	0	2588
Grand Total	0	0	0	0	585	841	652	0	2078	0	2253	214	151	2618	0	0	0	0	0	0	0	0	0	4696
Apprch %	0	0	0	0	28.2	40.5	31.4	0		0	86.1	8.2	5.8		0	0	0	0	0	0	0	0	0	
Total %	0	0	0	0	12.5	17.9	13.9	0	44.3	0	48	4.6	3.2	55.7	0	0	0	0	0	0	0	0	0	

Start Time	7th ST Southbound				HARRISON ST Westbound					7th ST Northbound					HARRISON ST Eastbound				I-80 EB ON-RAMP Northeastbound				Int. Total
	RT	TH	LT	App. Total	RT	TH	to I-80	LT	App. Total	RT	TH	LT	to I-80	App. Total	RT	TH	LT	App. Total	RT	TH	LT	App. Total	

Peak Hour Analysis From 07:00 to 08:45 - Peak 1 of 1

Peak Hour for Entire Intersection Begins at 08:00

08:00	0	0	0	0	84	98	71	0	253	0	293	20	11	324	0	0	0	0	0	0	0	0	0	577
08:15	0	0	0	0	79	110	90	0	279	0	313	34	28	375	0	0	0	0	0	0	0	0	0	654
08:30	0	0	0	0	68	129	104	0	301	0	305	32	25	362	0	0	0	0	0	0	0	0	0	663
08:45	0	0	0	0	75	121	118	0	314	0	312	48	20	380	0	0	0	0	0	0	0	0	0	694
Total Volume	0	0	0	0	306	458	383	0	1147	0	1223	134	84	1441	0	0	0	0	0	0	0	0	0	2588
% App. Total	0	0	0	0	26.7	39.9	33.4	0		0	84.9	9.3	5.8		0	0	0	0	0	0	0	0	0	
PHF	.000	.000	.000	.000	.911	.888	.811	.000	.913	.000	.977	.698	.750	.948	.000	.000	.000	.000	.000	.000	.000	.000	.000	.932

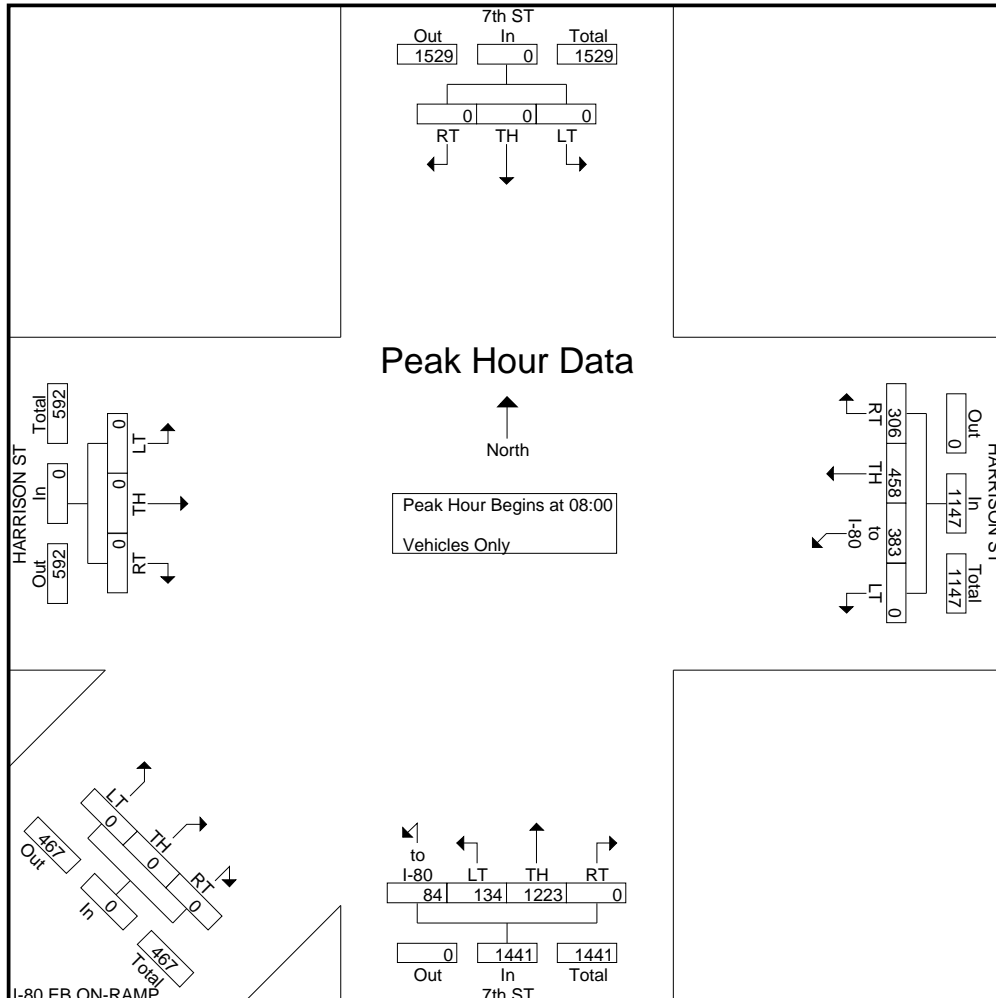

TRAFFIC COUNTS PLUS

mietekm@comcast.net
925.305.4358

CITY OF SAN FRANCISCO

File Name : 7-harrison-p

Latitude: 37.775525

Site Code : 3

Longitude: -122.406314

Start Date : 8/28/2018

Page No : 1

Groups Printed- Vehicles Only

Start Time	7th ST Southbound				HARRISON ST Westbound				7th ST Northbound				HARRISON ST Eastbound				I-80 EB ON-RAMP Northeastbound				Int. Total			
	RT	TH	LT	App. Total	RT	TH	to I-80	LT	App. Total	RT	TH	LT	to I-80	App. Total	RT	TH	LT	App. Total	RT	TH		LT	App. Total	
16:00	0	0	0	0	84	149	171	0	404	0	187	46	83	316	0	0	0	0	0	0	0	0	0	720
16:15	0	0	0	0	61	156	235	0	452	0	197	42	77	316	0	0	0	0	0	0	0	0	0	768
16:30	0	0	0	0	69	151	287	0	507	0	213	39	75	327	0	0	0	0	0	0	0	0	0	834
16:45	0	0	0	0	47	158	256	0	461	0	239	37	94	370	0	0	0	0	0	0	0	0	0	831
Total	0	0	0	0	261	614	949	0	1824	0	836	164	329	1329	0	0	0	0	0	0	0	0	0	3153
17:00	0	0	0	0	75	151	287	0	513	0	248	28	106	382	0	0	0	0	0	0	0	0	0	895
17:15	0	0	0	0	69	182	285	0	536	0	243	34	95	372	0	0	0	0	0	0	0	0	0	908
17:30	0	0	0	0	85	172	277	0	534	0	255	51	106	412	0	0	0	0	0	0	0	0	0	946
17:45	0	0	0	0	87	171	226	0	484	0	283	38	63	384	0	0	0	0	0	0	0	0	0	868
Total	0	0	0	0	316	676	1075	0	2067	0	1029	151	370	1550	0	0	0	0	0	0	0	0	0	3617
Grand Total	0	0	0	0	577	1290	2024	0	3891	0	1865	315	699	2879	0	0	0	0	0	0	0	0	0	6770
Apprch %	0	0	0	0	14.8	33.2	52	0		0	64.8	10.9	24.3		0	0	0	0	0	0	0	0	0	
Total %	0	0	0	0	8.5	19.1	29.9	0	57.5	0	27.5	4.7	10.3	42.5	0	0	0	0	0	0	0	0	0	

Start Time	7th ST Southbound				HARRISON ST Westbound				7th ST Northbound				HARRISON ST Eastbound				I-80 EB ON-RAMP Northeastbound				Int. Total
	RT	TH	LT	App. Total	RT	TH	to I-80	LT	App. Total	RT	TH	LT	to I-80	App. Total	RT	TH	LT	App. Total	RT	TH	

Peak Hour Analysis From 16:00 to 17:45 - Peak 1 of 1

Peak Hour for Entire Intersection Begins at 17:00

17:00	0	0	0	0	75	151	287	0	513	0	248	28	106	382	0	0	0	0	0	0	0	0	0	895
17:15	0	0	0	0	69	182	285	0	536	0	243	34	95	372	0	0	0	0	0	0	0	0	0	908
17:30	0	0	0	0	85	172	277	0	534	0	255	51	106	412	0	0	0	0	0	0	0	0	0	946
17:45	0	0	0	0	87	171	226	0	484	0	283	38	63	384	0	0	0	0	0	0	0	0	0	868
Total Volume	0	0	0	0	316	676	1075	0	2067	0	1029	151	370	1550	0	0	0	0	0	0	0	0	0	3617
% App. Total	0	0	0	0	15.3	32.7	52	0		0	66.4	9.7	23.9		0	0	0	0	0	0	0	0	0	
PHF	.000	.000	.000	.000	.908	.929	.936	.000	.964	.000	.909	.740	.873	.941	.000	.000	.000	.000	.000	.000	.000	.000	.000	.956

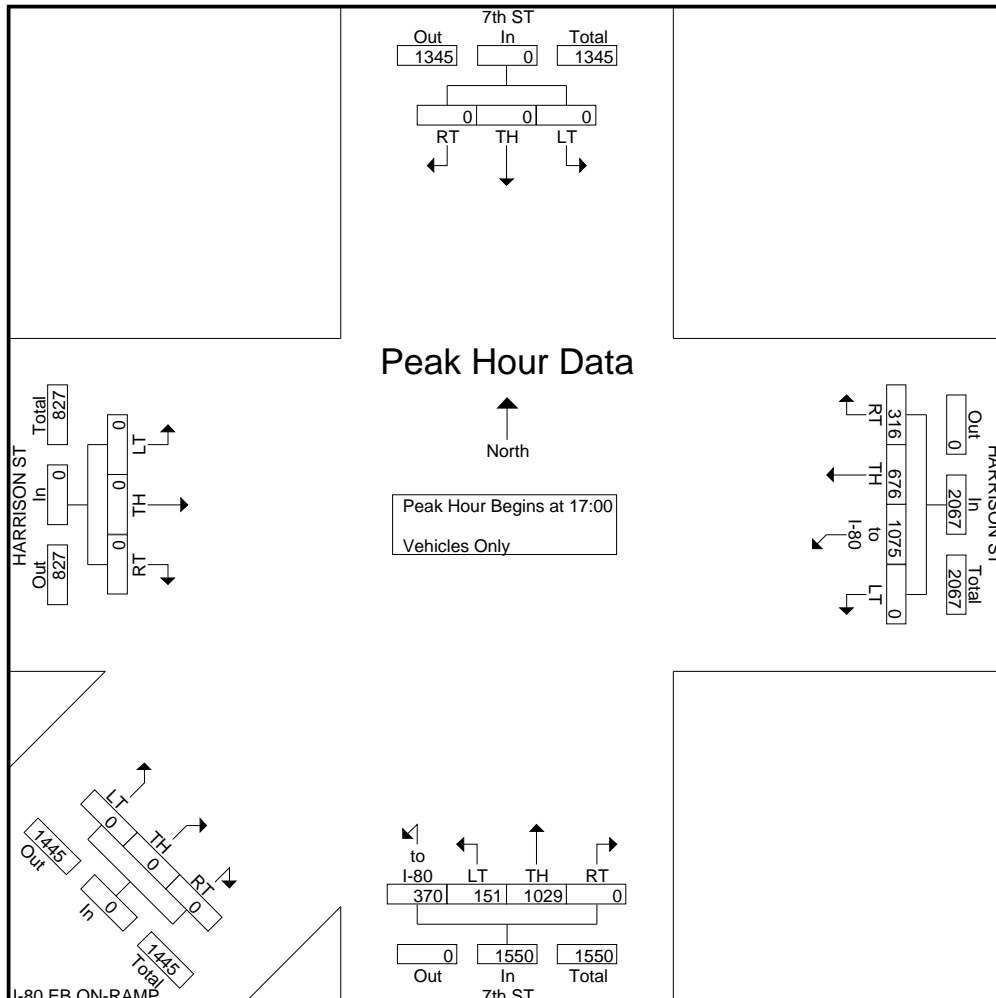

TRAFFIC COUNTS PLUS

mietekm@comcast.net
925.305.4358

CITY OF SAN FRANCISCO

Latitude: 37.770068
Longitude: -122.420080

File Name : mission-13-a
Site Code : 1
Start Date : 3/7/2018
Page No : 1

Groups Printed- Vehicles Only

Start Time	OTIS ST Southbound					13th ST Westbound				MISSION ST Northbound				DUBOCE AV Eastbound				US 101 NB OFF-RAMP Southwestbound				Int. Total
	RT	TH	LT	U-turn	App. Total	RT	TH	LT	App. Total	RT	TH	LT	App. Total	RT	TH	LT	App. Total	RT	TH	LT	App. Total	
07:00	13	57	180	18	268	0	84	0	84	47	48	0	95	6	184	0	190	217	131	0	348	985
07:15	16	55	169	13	253	0	119	0	119	54	68	0	122	6	197	0	203	219	135	0	354	1051
07:30	14	61	148	14	237	0	170	0	170	62	65	0	127	4	231	0	235	198	134	0	332	1101
07:45	15	76	147	13	251	0	178	0	178	71	81	0	152	7	184	0	191	186	115	0	301	1073
Total	58	249	644	58	1009	0	551	0	551	234	262	0	496	23	796	0	819	820	515	0	1335	4210
08:00	13	81	156	21	271	0	195	0	195	84	86	0	170	4	249	0	253	161	123	0	284	1173
08:15	13	57	166	13	249	0	172	0	172	85	103	0	188	4	270	0	274	150	132	0	282	1165
08:30	20	72	150	17	259	0	161	0	161	90	97	0	187	4	280	0	284	108	111	0	219	1110
08:45	19	80	179	11	289	0	182	0	182	71	96	0	167	8	294	0	302	147	117	0	264	1204
Total	65	290	651	62	1068	0	710	0	710	330	382	0	712	20	1093	0	1113	566	483	0	1049	4652
Grand Total	123	539	1295	120	2077	0	1261	0	1261	564	644	0	1208	43	1889	0	1932	1386	998	0	2384	8862
Apprch %	5.9	26	62.3	5.8		0	100	0		46.7	53.3	0		2.2	97.8	0		58.1	41.9	0		
Total %	1.4	6.1	14.6	1.4	23.4	0	14.2	0	14.2	6.4	7.3	0	13.6	0.5	21.3	0	21.8	15.6	11.3	0	26.9	

Start Time	OTIS ST Southbound					13th ST Westbound				MISSION ST Northbound				DUBOCE AV Eastbound				US 101 NB OFF-RAMP Southwestbound				Int. Total
	RT	TH	LT	U-turn	App. Total	RT	TH	LT	App. Total	RT	TH	LT	App. Total	RT	TH	LT	App. Total	RT	TH	LT	App. Total	

Peak Hour Analysis From 07:00 to 08:45 - Peak 1 of 1

Peak Hour for Entire Intersection Begins at 08:00

08:00	13	81	156	21	271	0	195	0	195	84	86	0	170	4	249	0	253	161	123	0	284	1173
08:15	13	57	166	13	249	0	172	0	172	85	103	0	188	4	270	0	274	150	132	0	282	1165
08:30	20	72	150	17	259	0	161	0	161	90	97	0	187	4	280	0	284	108	111	0	219	1110
08:45	19	80	179	11	289	0	182	0	182	71	96	0	167	8	294	0	302	147	117	0	264	1204
Total Volume	65	290	651	62	1068	0	710	0	710	330	382	0	712	20	1093	0	1113	566	483	0	1049	4652
% App. Total	6.1	27.2	61	5.8		0	100	0		46.3	53.7	0		1.8	98.2	0		54	46	0		
PHF	.813	.895	.909	.738	.924	.000	.910	.000	.910	.917	.927	.000	.947	.625	.929	.000	.921	.879	.915	.000	.923	.966

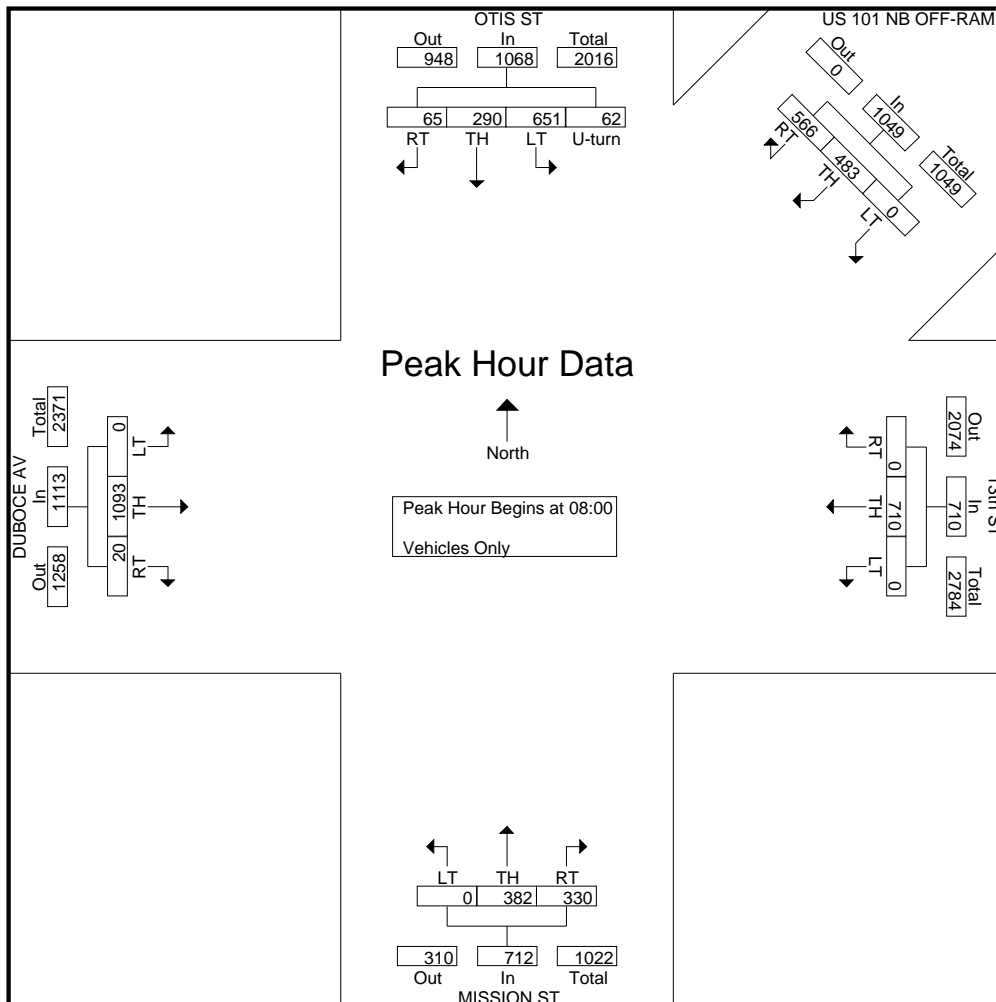

TRAFFIC COUNTS PLUS

mietekm@comcast.net
925.305.4358

CITY OF SAN FRANCISCO

Latitude: 37.770068
Longitude: -122.420080

File Name : mission-13-p
Site Code : 1
Start Date : 3/7/2018
Page No : 1

Groups Printed- Vehicles Only

Start Time	OTIS ST Southbound					13th ST Westbound				MISSION ST Northbound				DUBOCE AV Eastbound				US 101 NB OFF-RAMP Southwestbound				Int. Total
	RT	TH	LT	U-turn	App. Total	RT	TH	LT	App. Total	RT	TH	LT	App. Total	RT	TH	LT	App. Total	RT	TH	LT	App. Total	
16:00	21	88	151	16	276	0	199	0	199	29	54	0	83	5	146	0	151	64	125	0	189	898
16:15	26	89	147	19	281	0	204	0	204	31	75	0	106	5	130	0	135	164	120	0	284	1010
16:30	22	96	154	18	290	0	230	0	230	20	67	0	87	7	141	0	148	206	128	0	334	1089
16:45	43	120	159	14	336	0	249	0	249	27	81	0	108	3	128	0	131	187	106	0	293	1117
Total	112	393	611	67	1183	0	882	0	882	107	277	0	384	20	545	0	565	621	479	0	1100	4114
17:00	42	103	161	11	317	0	242	0	242	29	72	0	101	14	161	0	175	195	119	0	314	1149
17:15	30	121	146	13	310	0	221	0	221	42	81	0	123	7	140	0	147	195	90	0	285	1086
17:30	34	130	145	8	317	0	206	0	206	25	79	0	104	5	147	0	152	179	101	0	280	1059
17:45	32	141	166	5	344	0	210	0	210	24	71	0	95	8	141	0	149	139	106	0	245	1043
Total	138	495	618	37	1288	0	879	0	879	120	303	0	423	34	589	0	623	708	416	0	1124	4337
Grand Total	250	888	1229	104	2471	0	1761	0	1761	227	580	0	807	54	1134	0	1188	1329	895	0	2224	8451
Apprch %	10.1	35.9	49.7	4.2		0	100	0		28.1	71.9	0		4.5	95.5	0		59.8	40.2	0		
Total %	3	10.5	14.5	1.2	29.2	0	20.8	0	20.8	2.7	6.9	0	9.5	0.6	13.4	0	14.1	15.7	10.6	0	26.3	

Start Time	OTIS ST Southbound					13th ST Westbound				MISSION ST Northbound				DUBOCE AV Eastbound				US 101 NB OFF-RAMP Southwestbound				Int. Total
	RT	TH	LT	U-turn	App. Total	RT	TH	LT	App. Total	RT	TH	LT	App. Total	RT	TH	LT	App. Total	RT	TH	LT	App. Total	

Peak Hour Analysis From 16:00 to 17:45 - Peak 1 of 1

Peak Hour for Entire Intersection Begins at 16:30

16:30	22	96	154	18	290	0	230	0	230	20	67	0	87	7	141	0	148	206	128	0	334	1089
16:45	43	120	159	14	336	0	249	0	249	27	81	0	108	3	128	0	131	187	106	0	293	1117
17:00	42	103	161	11	317	0	242	0	242	29	72	0	101	14	161	0	175	195	119	0	314	1149
17:15	30	121	146	13	310	0	221	0	221	42	81	0	123	7	140	0	147	195	90	0	285	1086
Total Volume	137	440	620	56	1253	0	942	0	942	118	301	0	419	31	570	0	601	783	443	0	1226	4441
% App. Total	10.9	35.1	49.5	4.5		0	100	0		28.2	71.8	0		5.2	94.8	0		63.9	36.1	0		
PHF	.797	.909	.963	.778	.932	.000	.946	.000	.946	.702	.929	.000	.852	.554	.885	.000	.859	.950	.865	.000	.918	.966

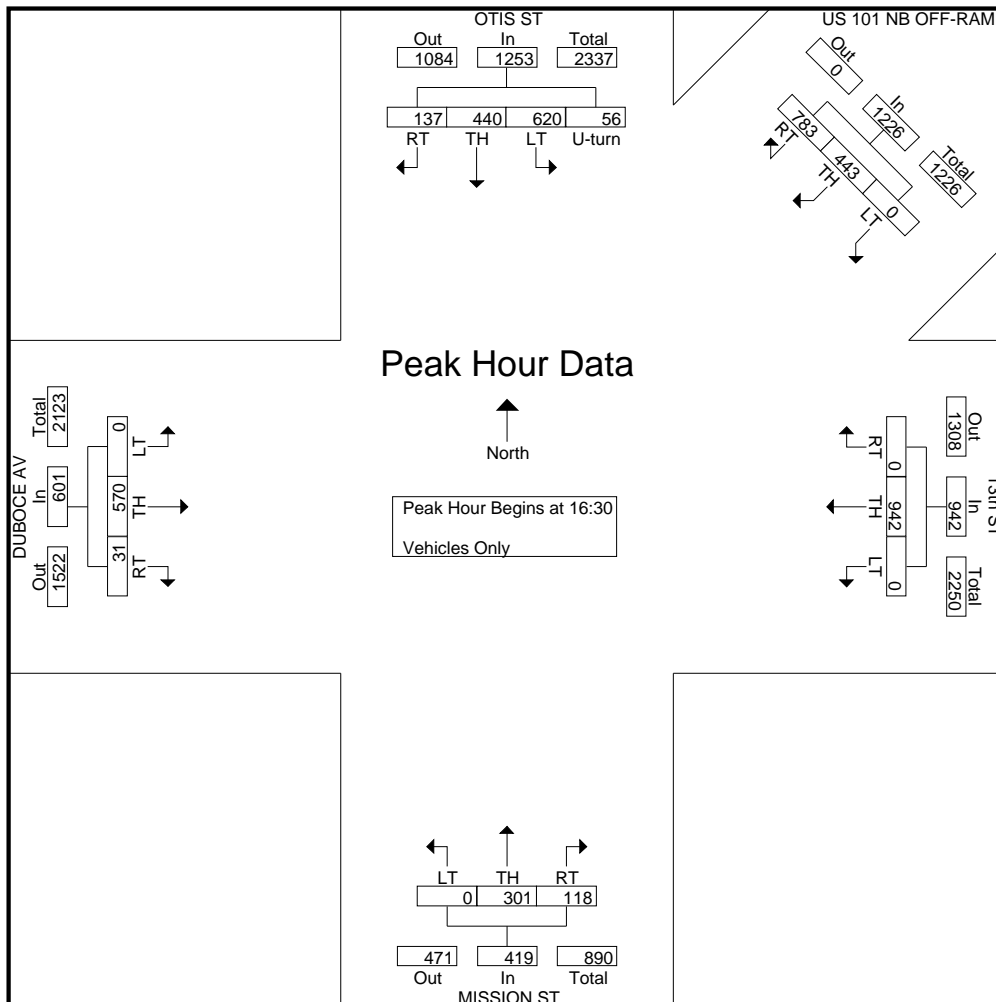

TRAFFIC COUNTS PLUS

mietekm@comcast.net
925.305.4358

CITY OF SAN FRANCISCO

File Name : van ness-13-a

Latitude: 37.769827

Site Code : 2

Longitude: -122.417807

Start Date : 3/7/2018

Page No : 1

Groups Printed- Vehicles Only

Start Time	S. VAN NESS AV Southbound				13th ST Westbound				S. VAN NESS AV Northbound				13th ST Eastbound				Int. Total
	RT	TH	LT	App. Total	RT	TH	LT	App. Total	RT	TH	LT	App. Total	RT	TH	LT	App. Total	
07:00	13	265	31	309	29	70	22	121	16	63	0	79	308	109	0	417	926
07:15	23	253	27	303	34	95	15	144	18	99	0	117	302	112	0	414	978
07:30	15	241	38	294	41	150	17	208	22	109	0	131	312	135	0	447	1080
07:45	25	238	27	290	31	156	15	202	34	142	0	176	322	113	0	435	1103
Total	76	997	123	1196	135	471	69	675	90	413	0	503	1244	469	0	1713	4087
08:00	27	249	29	305	37	164	23	224	34	126	0	160	343	146	0	489	1178
08:15	18	236	19	273	35	150	24	209	47	143	0	190	339	171	0	510	1182
08:30	15	246	30	291	36	136	33	205	45	140	0	185	358	186	0	544	1225
08:45	20	239	33	292	57	138	24	219	36	166	0	202	340	196	0	536	1249
Total	80	970	111	1161	165	588	104	857	162	575	0	737	1380	699	0	2079	4834
Grand Total	156	1967	234	2357	300	1059	173	1532	252	988	0	1240	2624	1168	0	3792	8921
Apprch %	6.6	83.5	9.9		19.6	69.1	11.3		20.3	79.7	0		69.2	30.8	0		
Total %	1.7	22	2.6	26.4	3.4	11.9	1.9	17.2	2.8	11.1	0	13.9	29.4	13.1	0	42.5	

Start Time	S. VAN NESS AV Southbound				13th ST Westbound				S. VAN NESS AV Northbound				13th ST Eastbound				Int. Total
	RT	TH	LT	App. Total	RT	TH	LT	App. Total	RT	TH	LT	App. Total	RT	TH	LT	App. Total	
08:00	27	249	29	305	37	164	23	224	34	126	0	160	343	146	0	489	1178
08:15	18	236	19	273	35	150	24	209	47	143	0	190	339	171	0	510	1182
08:30	15	246	30	291	36	136	33	205	45	140	0	185	358	186	0	544	1225
08:45	20	239	33	292	57	138	24	219	36	166	0	202	340	196	0	536	1249
Total Volume	80	970	111	1161	165	588	104	857	162	575	0	737	1380	699	0	2079	4834
% App. Total	6.9	83.5	9.6		19.3	68.6	12.1		22	78	0		66.4	33.6	0		
PHF	.741	.974	.841	.952	.724	.896	.788	.956	.862	.866	.000	.912	.964	.892	.000	.955	.968

Peak Hour Analysis From 07:00 to 08:45 - Peak 1 of 1

Peak Hour for Entire Intersection Begins at 08:00

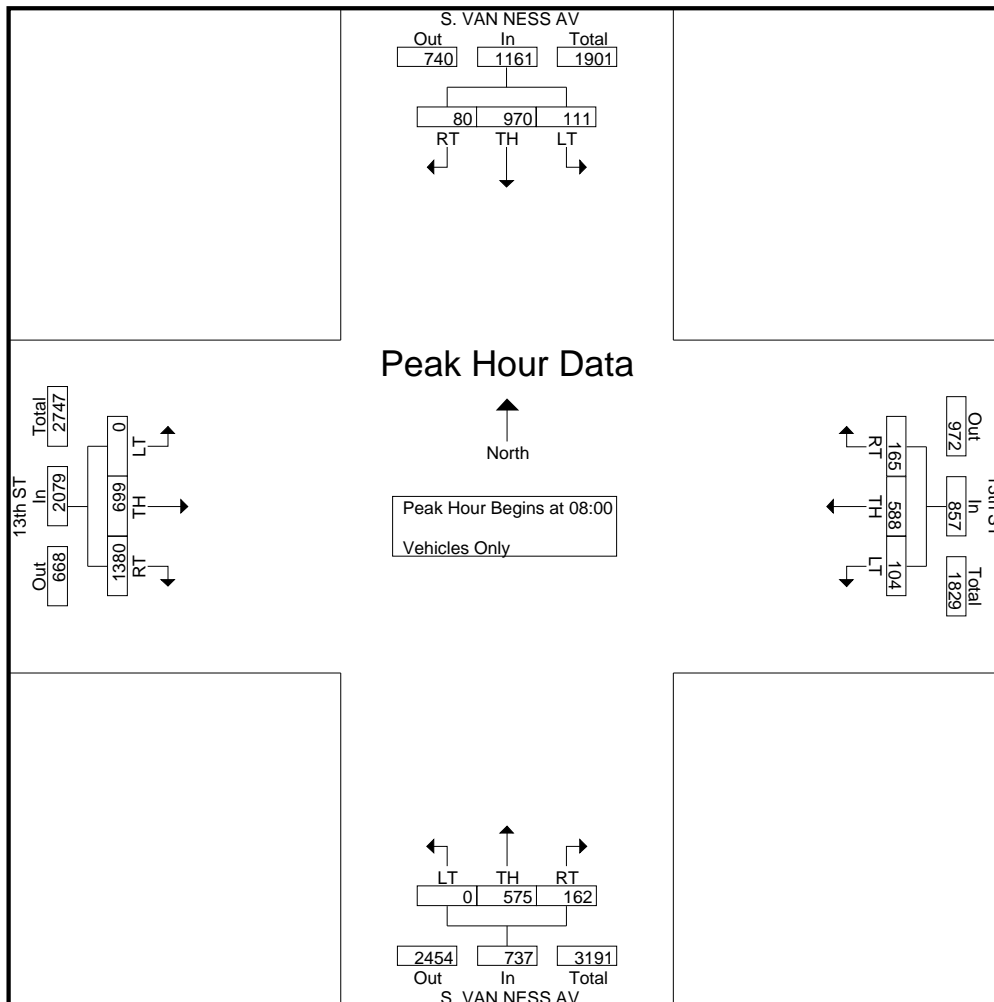

TRAFFIC COUNTS PLUS

mietekm@comcast.net
925.305.4358

CITY OF SAN FRANCISCO

Latitude: 37.769827
Longitude: -122.417807

File Name : van ness-13-p
Site Code : 2
Start Date : 3/7/2018
Page No : 1

Groups Printed- Vehicles Only

Start Time	S. VAN NESS AV Southbound				13th ST Westbound				S. VAN NESS AV Northbound				13th ST Eastbound				Int. Total
	RT	TH	LT	App. Total	RT	TH	LT	App. Total	RT	TH	LT	App. Total	RT	TH	LT	App. Total	
16:00	13	282	10	305	55	183	52	290	30	111	0	141	202	156	0	358	1094
16:15	15	280	4	299	42	192	40	274	28	119	0	147	191	125	0	316	1036
16:30	23	285	3	311	35	201	36	272	22	107	0	129	195	147	0	342	1054
16:45	29	284	7	320	47	213	37	297	24	89	0	113	184	158	0	342	1072
Total	80	1131	24	1235	179	789	165	1133	104	426	0	530	772	586	0	1358	4256
17:00	25	302	5	332	73	214	64	351	24	102	0	126	204	175	0	379	1188
17:15	19	292	2	313	59	206	65	330	31	129	0	160	232	145	0	377	1180
17:30	15	262	10	287	56	187	64	307	23	123	0	146	180	169	0	349	1089
17:45	13	280	7	300	41	186	55	282	40	77	0	117	174	161	0	335	1034
Total	72	1136	24	1232	229	793	248	1270	118	431	0	549	790	650	0	1440	4491
Grand Total	152	2267	48	2467	408	1582	413	2403	222	857	0	1079	1562	1236	0	2798	8747
Apprch %	6.2	91.9	1.9		17	65.8	17.2		20.6	79.4	0		55.8	44.2	0		
Total %	1.7	25.9	0.5	28.2	4.7	18.1	4.7	27.5	2.5	9.8	0	12.3	17.9	14.1	0	32	

Start Time	S. VAN NESS AV Southbound				13th ST Westbound				S. VAN NESS AV Northbound				13th ST Eastbound				Int. Total
	RT	TH	LT	App. Total	RT	TH	LT	App. Total	RT	TH	LT	App. Total	RT	TH	LT	App. Total	
16:45	29	284	7	320	47	213	37	297	24	89	0	113	184	158	0	342	1072
17:00	25	302	5	332	73	214	64	351	24	102	0	126	204	175	0	379	1188
17:15	19	292	2	313	59	206	65	330	31	129	0	160	232	145	0	377	1180
17:30	15	262	10	287	56	187	64	307	23	123	0	146	180	169	0	349	1089
Total Volume	88	1140	24	1252	235	820	230	1285	102	443	0	545	800	647	0	1447	4529
% App. Total	7	91.1	1.9		18.3	63.8	17.9		18.7	81.3	0		55.3	44.7	0		
PHF	.759	.944	.600	.943	.805	.958	.885	.915	.823	.859	.000	.852	.862	.924	.000	.954	.953

Peak Hour Analysis From 16:00 to 17:45 - Peak 1 of 1
Peak Hour for Entire Intersection Begins at 16:45

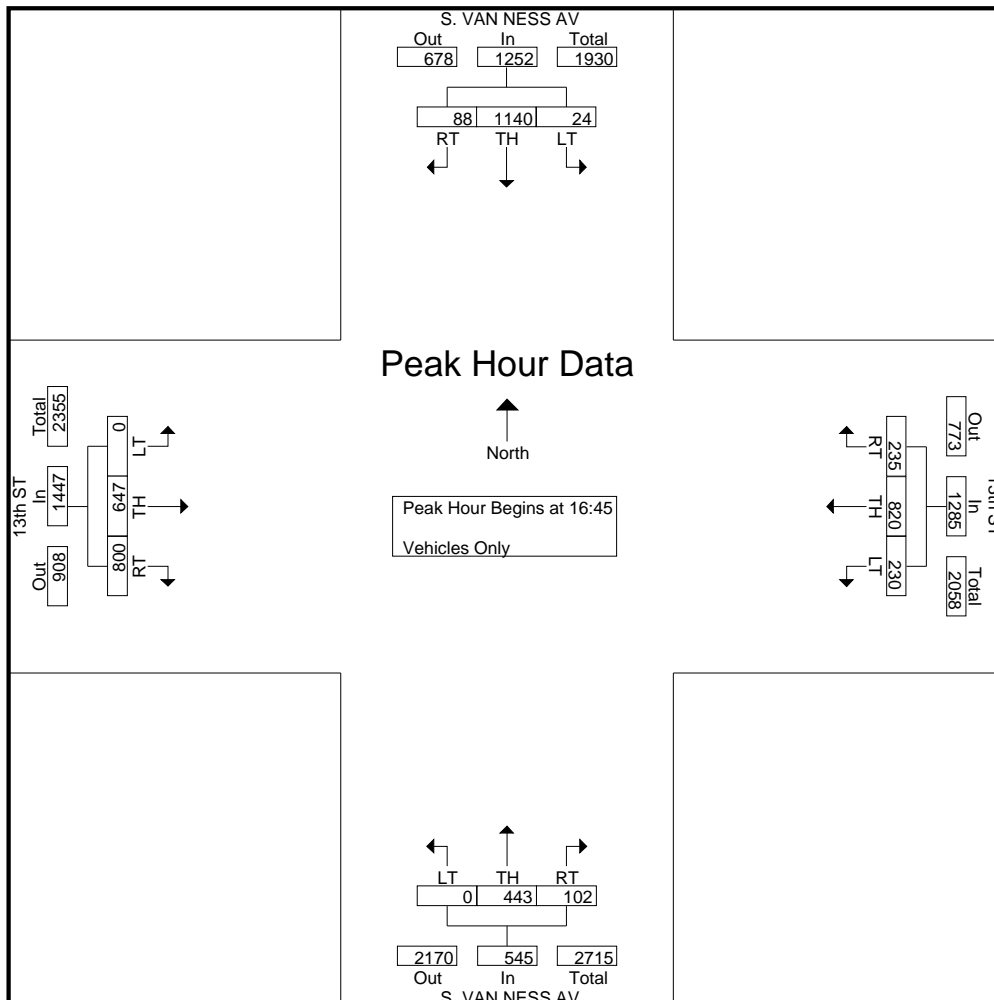

TRAFFIC COUNTS PLUS

mietekm@comcast.net
925.305.4358

CITY OF SAN FRANCISCO

Latitude: 37.769217
Longitude: -122.417834

File Name : van ness-erie-a
Site Code : 3
Start Date : 3/7/2018
Page No : 1

Groups Printed- Vehicles Only

Start Time	S. VAN NESS AV Southbound				ERIE ST Westbound				S. VAN NESS AV Northbound				I-80 EB ON-RAMP Eastbound				Int. Total
	RT	TH	LT	App. Total	RT	TH	LT	App. Total	RT	TH	LT	App. Total	RT	TH	LT	App. Total	
07:00	517	89	0	606	0	0	0	0	0	83	0	83	0	0	0	0	689
07:15	494	78	0	572	1	0	0	1	0	119	0	119	0	0	0	0	692
07:30	498	77	0	575	0	0	0	0	0	137	0	137	0	0	0	0	712
07:45	491	90	0	581	0	0	0	0	1	178	0	179	0	0	0	0	760
Total	2000	334	0	2334	1	0	0	1	1	517	0	518	0	0	0	0	2853
08:00	537	96	0	633	0	0	0	0	0	168	0	168	0	0	0	0	801
08:15	509	94	0	603	0	0	0	0	0	188	0	188	0	0	0	0	791
08:30	541	101	0	642	1	0	0	1	1	187	0	188	0	0	0	0	831
08:45	513	90	0	603	0	0	0	0	2	201	0	203	0	0	0	0	806
Total	2100	381	0	2481	1	0	0	1	3	744	0	747	0	0	0	0	3229
Grand Total	4100	715	0	4815	2	0	0	2	4	1261	0	1265	0	0	0	0	6082
Apprch %	85.2	14.8	0		100	0	0		0.3	99.7	0		0	0	0		
Total %	67.4	11.8	0	79.2	0	0	0	0	0.1	20.7	0	20.8	0	0	0	0	

Start Time	S. VAN NESS AV Southbound				ERIE ST Westbound				S. VAN NESS AV Northbound				I-80 EB ON-RAMP Eastbound				Int. Total
	RT	TH	LT	App. Total	RT	TH	LT	App. Total	RT	TH	LT	App. Total	RT	TH	LT	App. Total	
08:00	537	96	0	633	0	0	0	0	0	168	0	168	0	0	0	0	801
08:15	509	94	0	603	0	0	0	0	0	188	0	188	0	0	0	0	791
08:30	541	101	0	642	1	0	0	1	1	187	0	188	0	0	0	0	831
08:45	513	90	0	603	0	0	0	0	2	201	0	203	0	0	0	0	806
Total Volume	2100	381	0	2481	1	0	0	1	3	744	0	747	0	0	0	0	3229
% App. Total	84.6	15.4	0		100	0	0		0.4	99.6	0		0	0	0		
PHF	.970	.943	.000	.966	.250	.000	.000	.250	.375	.925	.000	.920	.000	.000	.000	.000	.971

Peak Hour Analysis From 07:00 to 08:45 - Peak 1 of 1

Peak Hour for Entire Intersection Begins at 08:00

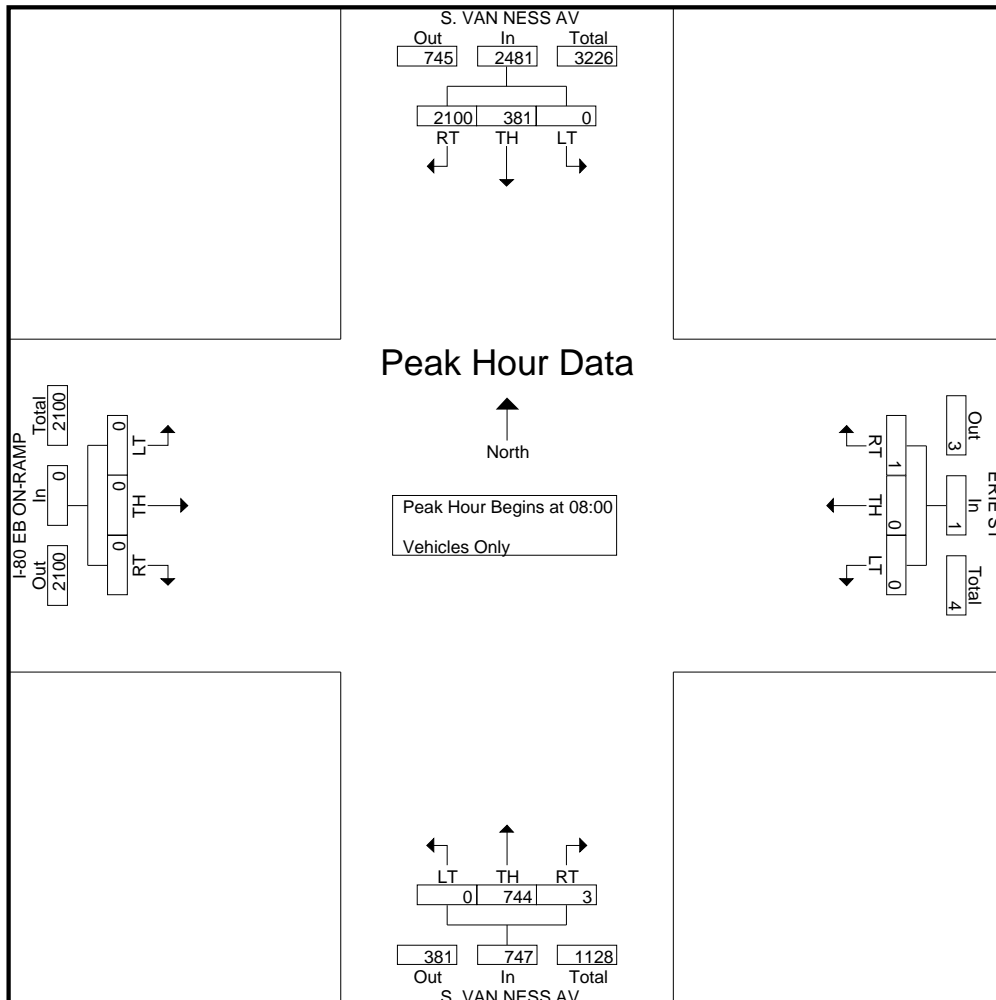

TRAFFIC COUNTS PLUS

mietekm@comcast.net
925.305.4358

CITY OF SAN FRANCISCO

Latitude: 37.769217
Longitude: -122.417834

File Name : van ness-erie-p
Site Code : 3
Start Date : 3/7/2018
Page No : 1

Groups Printed- Vehicles Only

Start Time	S. VAN NESS AV Southbound				ERIE ST Westbound				S. VAN NESS AV Northbound				I-80 EB ON-RAMP Eastbound				Int. Total
	RT	TH	LT	App. Total	RT	TH	LT	App. Total	RT	TH	LT	App. Total	RT	TH	LT	App. Total	
16:00	351	181	0	532	0	0	0	0	0	143	0	143	0	0	0	0	675
16:15	355	155	0	510	1	0	0	1	1	143	0	144	0	0	0	0	655
16:30	333	186	0	519	0	0	0	0	1	125	0	126	0	0	0	0	645
16:45	305	201	0	506	1	0	0	1	0	122	0	122	0	0	0	0	629
Total	1344	723	0	2067	2	0	0	2	2	533	0	535	0	0	0	0	2604
17:00	399	175	0	574	0	0	0	0	1	130	0	131	0	0	0	0	705
17:15	401	193	0	594	1	0	0	1	1	158	0	159	0	0	0	0	754
17:30	298	212	0	510	0	0	0	0	0	135	0	135	0	0	0	0	645
17:45	287	266	0	553	0	0	0	0	0	122	0	122	0	0	0	0	675
Total	1385	846	0	2231	1	0	0	1	2	545	0	547	0	0	0	0	2779
Grand Total	2729	1569	0	4298	3	0	0	3	4	1078	0	1082	0	0	0	0	5383
Apprch %	63.5	36.5	0		100	0	0		0.4	99.6	0		0	0	0		
Total %	50.7	29.1	0	79.8	0.1	0	0	0.1	0.1	20	0	20.1	0	0	0	0	

Start Time	S. VAN NESS AV Southbound				ERIE ST Westbound				S. VAN NESS AV Northbound				I-80 EB ON-RAMP Eastbound				Int. Total
	RT	TH	LT	App. Total	RT	TH	LT	App. Total	RT	TH	LT	App. Total	RT	TH	LT	App. Total	
17:00	399	175	0	574	0	0	0	0	1	130	0	131	0	0	0	0	705
17:15	401	193	0	594	1	0	0	1	1	158	0	159	0	0	0	0	754
17:30	298	212	0	510	0	0	0	0	0	135	0	135	0	0	0	0	645
17:45	287	266	0	553	0	0	0	0	0	122	0	122	0	0	0	0	675
Total Volume	1385	846	0	2231	1	0	0	1	2	545	0	547	0	0	0	0	2779
% App. Total	62.1	37.9	0		100	0	0		0.4	99.6	0		0	0	0		
PHF	.863	.795	.000	.939	.250	.000	.000	.250	.500	.862	.000	.860	.000	.000	.000	.000	.921

Peak Hour Analysis From 16:00 to 17:45 - Peak 1 of 1
Peak Hour for Entire Intersection Begins at 17:00

